

# M9400 SOFTLINE PLUS

Oktobar 2012.god



# Profili Profiles

1:1

### M 9300

W=756 gr/m

ŠTOK RAVNI-MALI  
FRAME SMALL FLAT

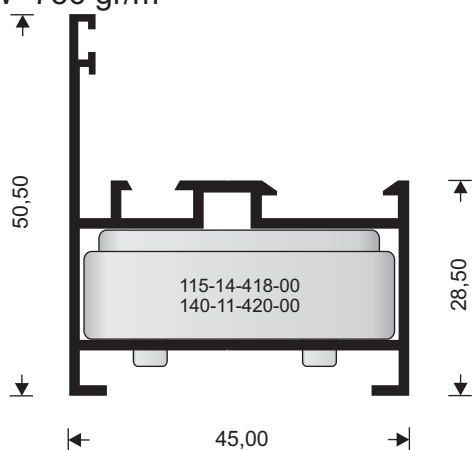

### M 9424

W=1209 gr/m

ŠTOK ZAoblJENI-SREDNJI  
FRAME ROUND MEDIUM

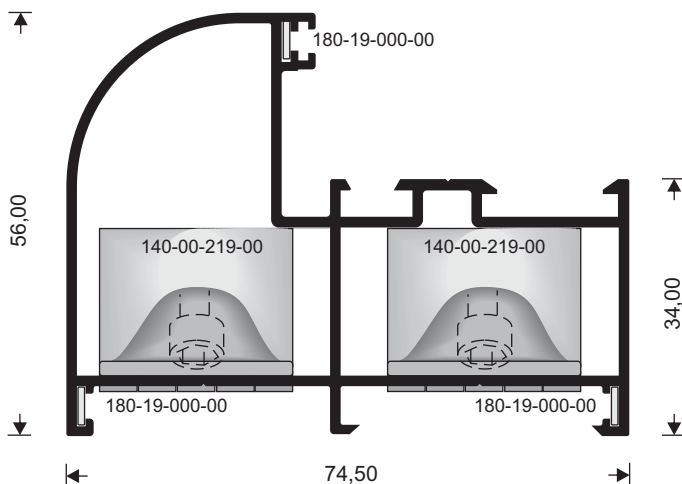

### BHS 4645

W=889 gr/m

RAVNII ŠTOK  
FRAME FLAT

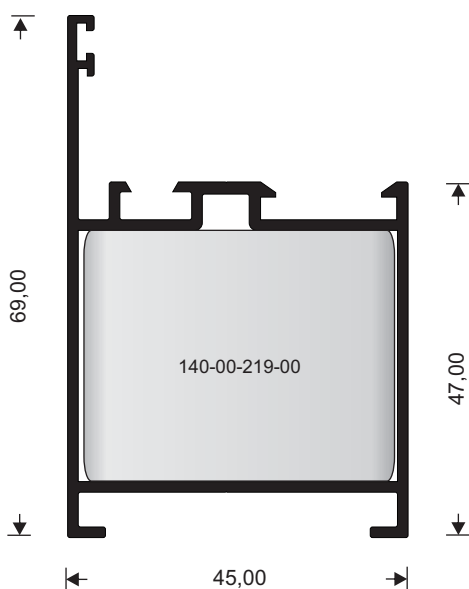

### M 9518

W=1035 gr/m

ŠTOK ZAoblJENI-VELIKI  
FRAME ROUND LARGE

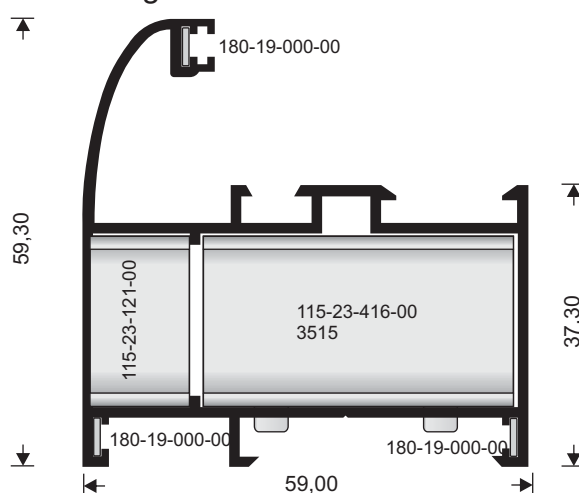

### M 9536

W=1035 gr/m

Z-ŠTOK  
"Z" FRAME

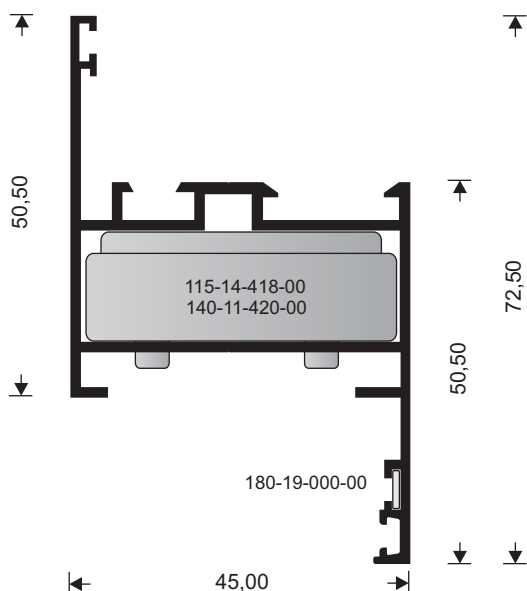

### BH 18

W=1095 gr/m

ŠTOK ZAoblJENI  
FRAME ROUND

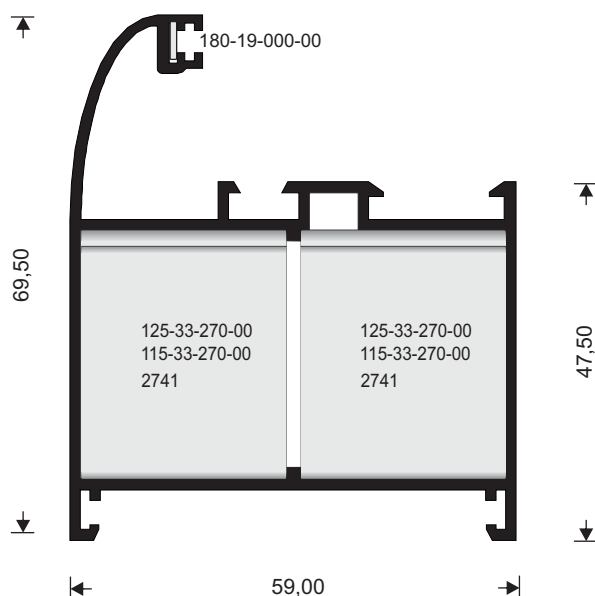

**M 9130**

W=1630 gr/m

OJAČANI ŠTOK  
FRAME LARGE FLAT

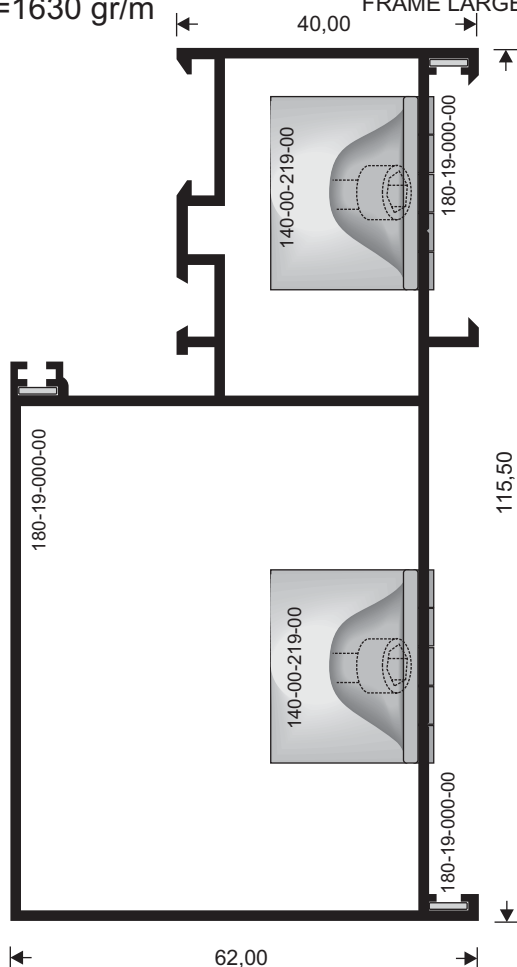

**NAMJENJENO ZA IZLOGE:**  
ŠTOK M9130 MOŽE SE KORISTITI  
U KOMBINACIJI SA "T" PREČKAMA  
M9132 (KAO VERTIKALA)  
I M9485 (KAO HORIZONTALA)  
ZA IZRADU IZLOGA.

**CONSTRUCTIVE SOLUTION  
FOR SHOPFRONTS:**  
THE FRAME M9130 CAN BE USED  
IN CONUCTION WITH "T" PROFILES  
M9132 (AS COLUMN)  
AND M9485 (AS TRANSVERSE)  
FOR THE CONSTRUCTION  
OF SHOPFRONTS.

**M 9502**

W=1088 gr/m

KRILO RAVNO-SREDNJE  
SASH MEDIUM FLAT

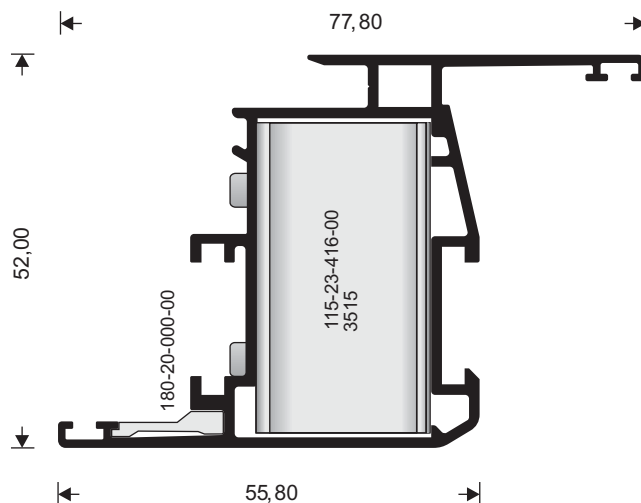

**M 9503**

W=1319 gr/m

KRILO RAVNO-VELIKO  
SASH LARGE FLAT

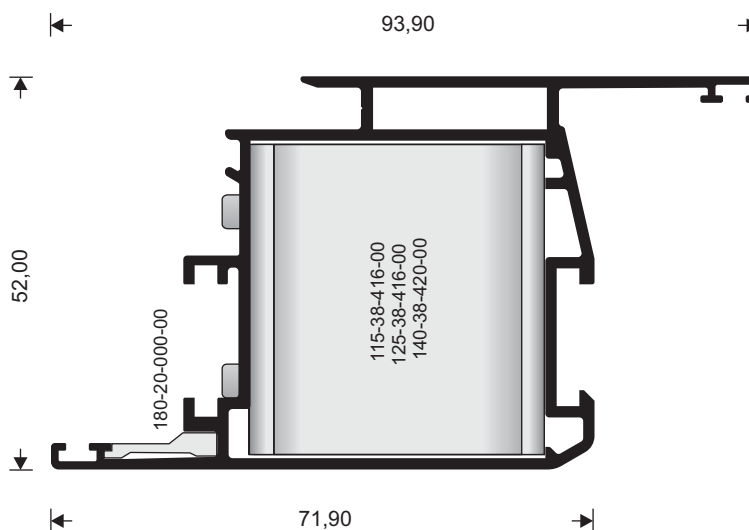

**M 9501**

W=966 gr/m

KRILO RAVNO-MALO  
SASH SMALL FLAT

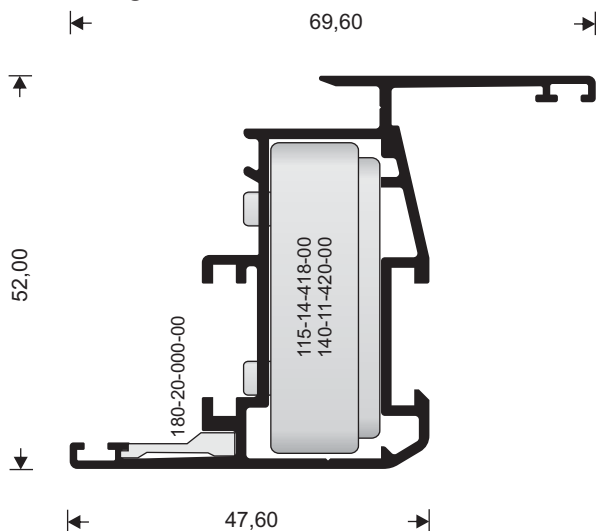

**M 9320**

W=859 gr/m

ŠTOK "CLASSIC"-MALI  
FRAME "CLASSIC" SMALL

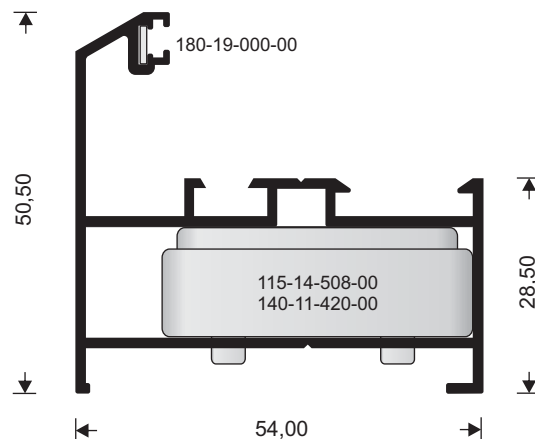

**M 9527** KRILO RAVNO-VELIKO OTVARANJE VANI  
W=1225 gr/m SASH LARGE FLAT OPENING OUT

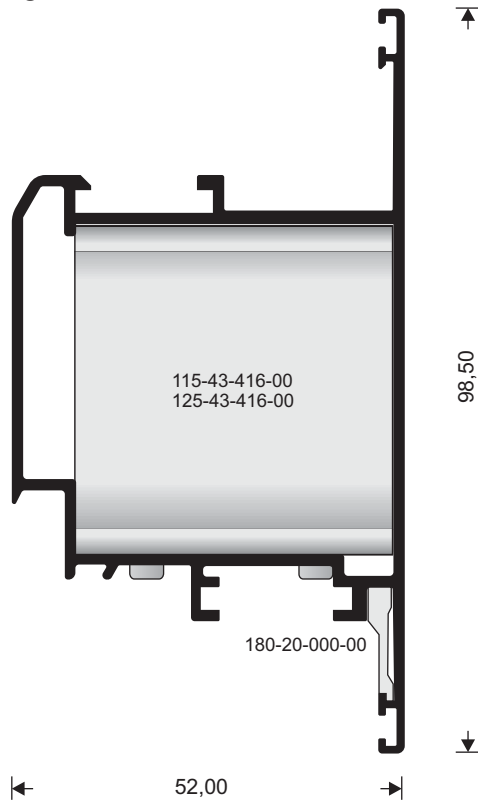

**M 9551** KRILO ZAoblJENO SREDNJE  
W=1078 gr/m SASH ROUND MEDIUM

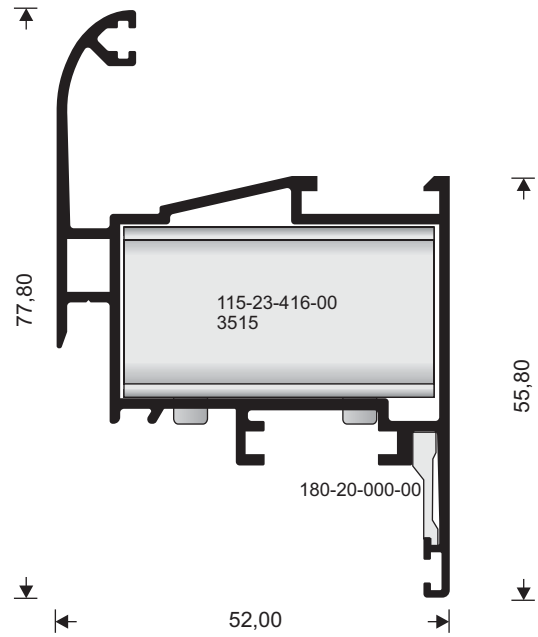

**M 9550** KRILO ZAoblJENO-SREDNJE  
W=967 gr/m SASH ROUND MEDIUM

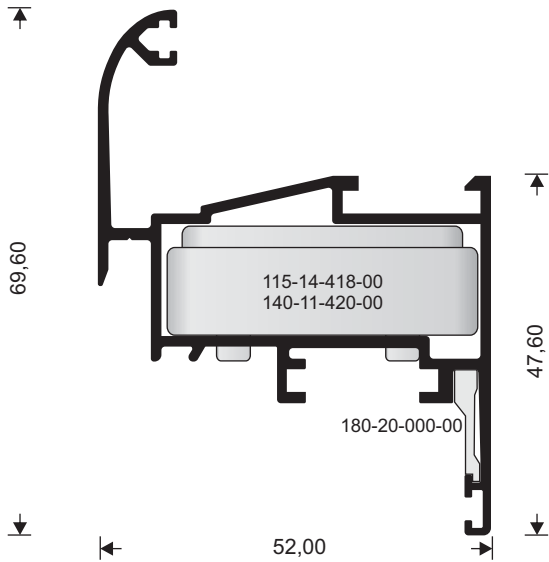

**M 9572** KRILO ZAoblJENO-VELIKO  
W=1332 gr/m SASH ROUND LARGE

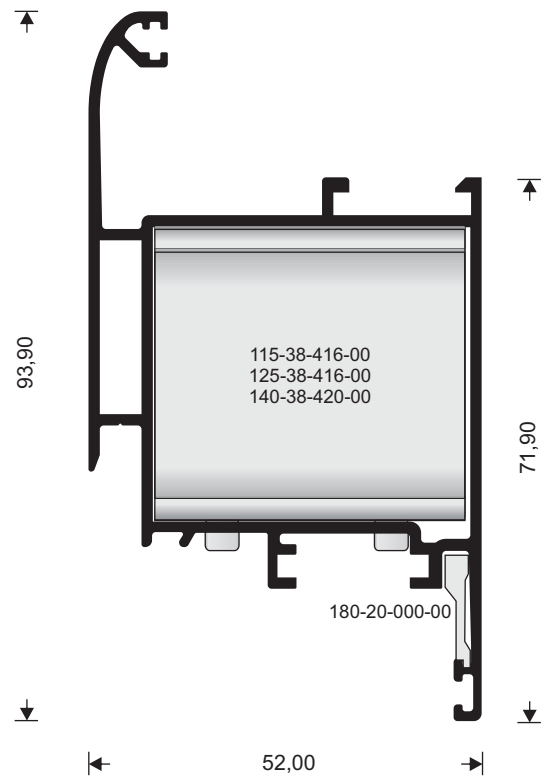

**M 9526**

ZAOKLJENO KRILLO-SREDNJE,  
OTVARANJE VANI

W=1032 gr/m SASH ROUND MEDIUM OP. OUTSIDE

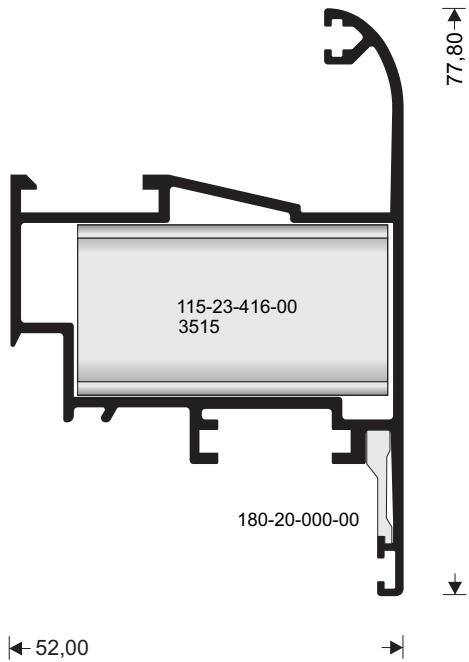

**M 9560**

KRILLO ZAOKLJENO-MALO  
SASH ROUND SMALL

W=1115 gr/m

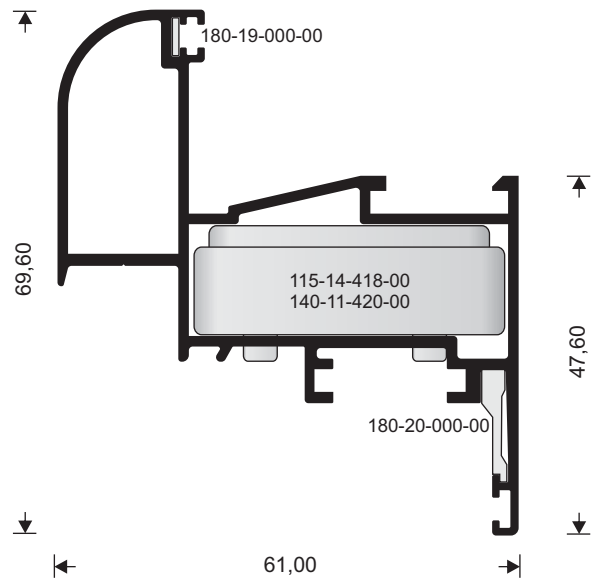

**M 9517**

ZAOKLJENO KRILLO-VELIKO  
ZA OTVARANJE VANI  
LARGE ROUND SASH  
OPENING OUTWARDS

W=1267 gr/m

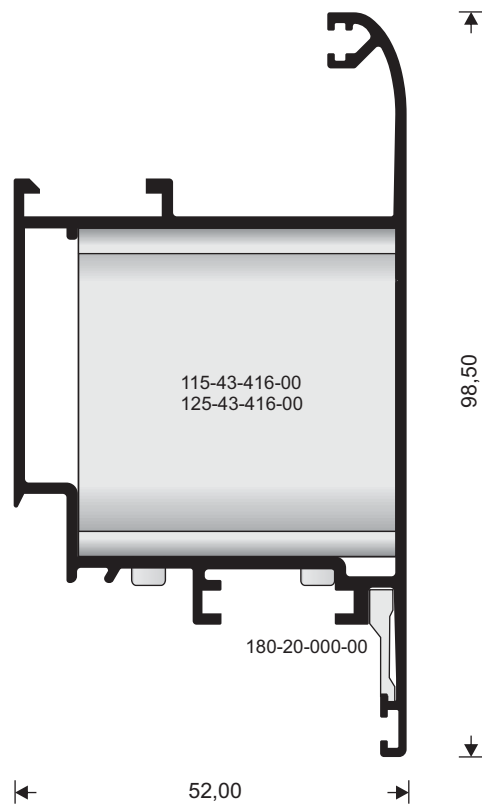

**M 9562**

ZAOKLJENO KRILLO-VELIKO  
SASH ROUND LARGE

W=1465 gr/m

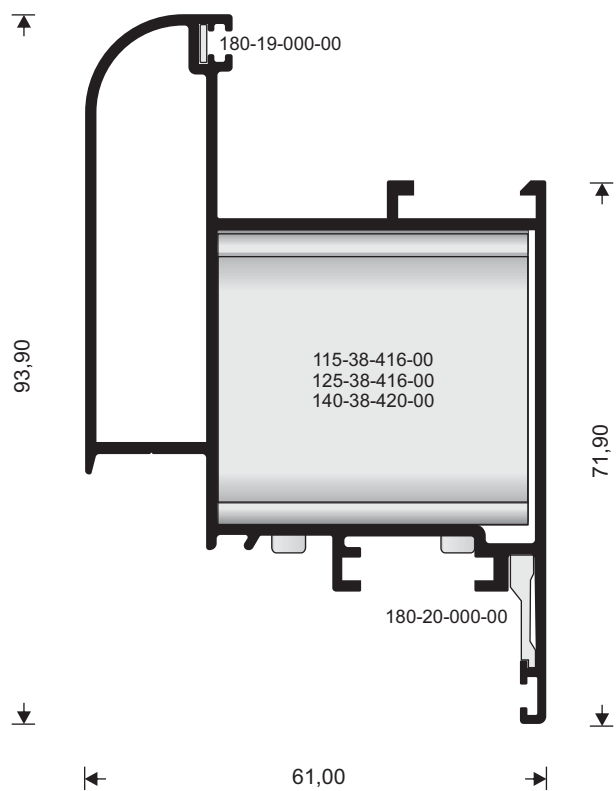

### M 9305

W=927 gr/m

"T" PREČKA  
"T" PROFILE

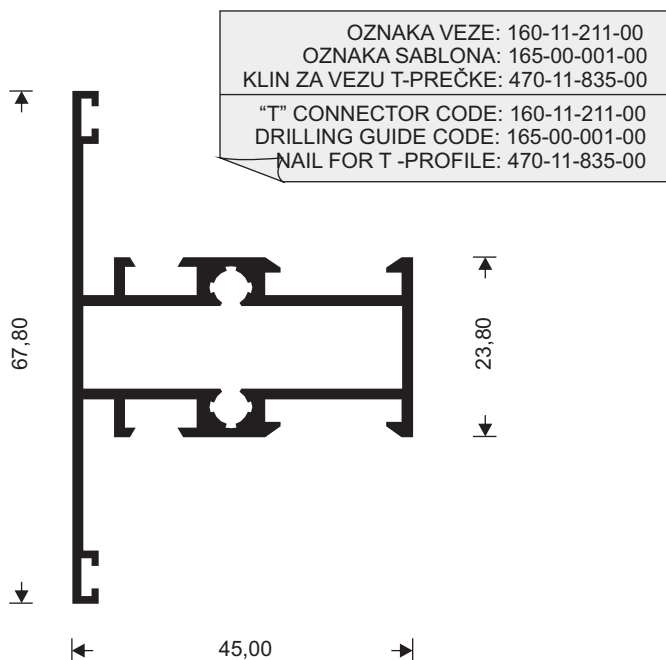

### BHT 4645

W=1034 gr/m

"T" PREČKA  
"T" PROFILE

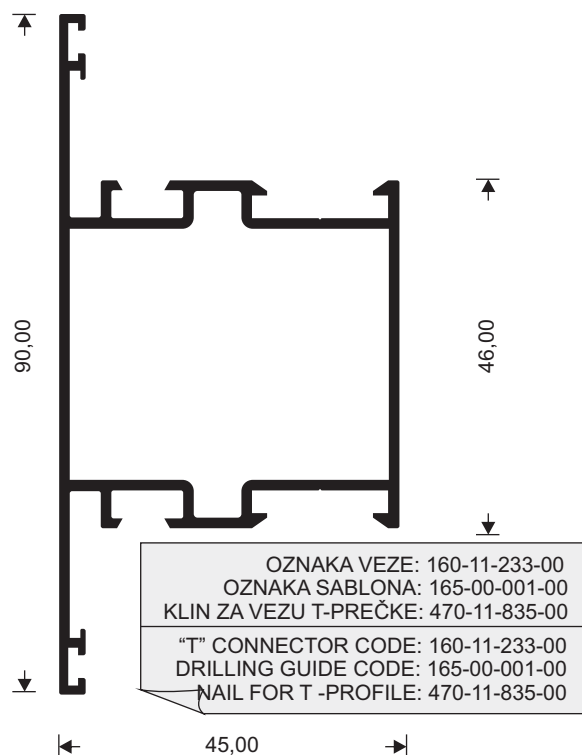

### M 9308

W=1166 gr/m

"T" PREČKA  
"T" PROFILE

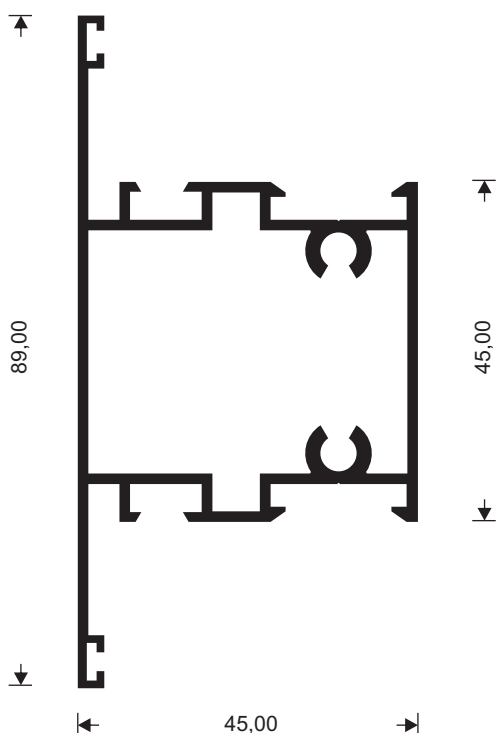

### M 9307

W=1264 gr/m

"T" PREČKA  
"T" PROFILE

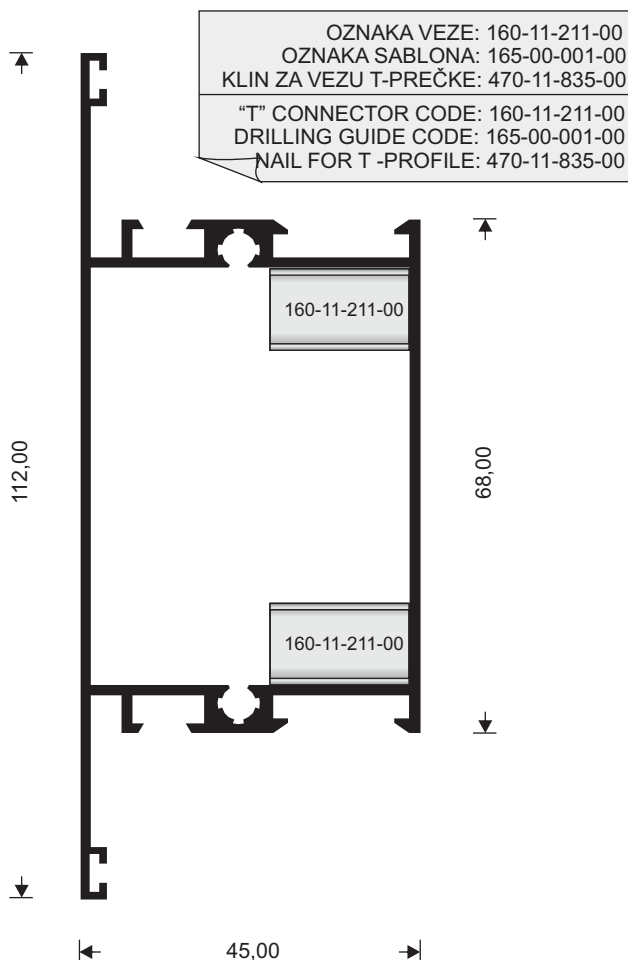

**M 9132**  
W=2539 gr/m

OJAČANA T PREČKA  
"T" PROFILE

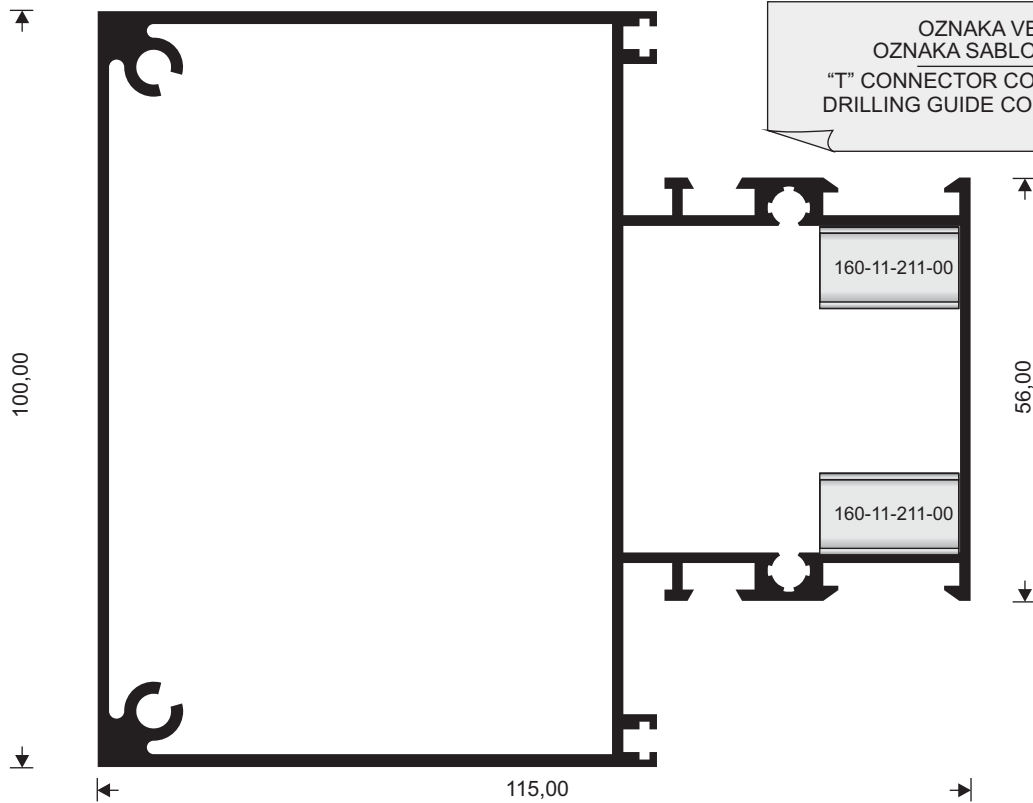

**M 9325**

DODATAK ZA ŠTOK  
FRAME

W=401 gr/m

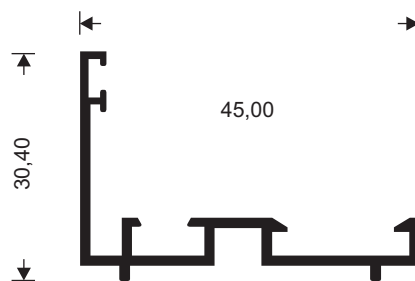

**M 9485**  
W=1438 gr/m

OJAČANA T PREČKA  
"T" PROFILE

OZNAKA VEZE: 160-11-211-00  
OZNAKA SABLONA: 165-00-001-00  
KLIN ZA VEZU T-PREČKE: 470-11-835-00  
"T" CONNECTOR CODE: 160-11-211-00  
DRILLING GUIDE CODE: 165-00-001-00  
NAIL FOR T -PROFILE: 470-11-835-00

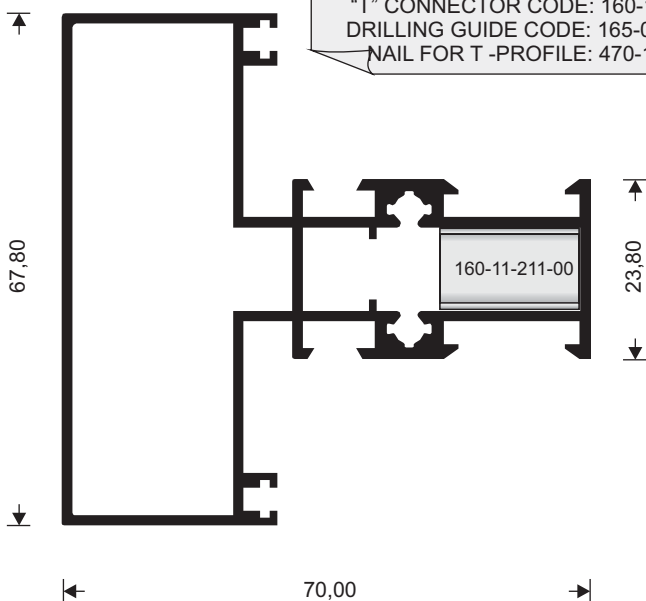

**M 9374**

PROFIL ZA PROMJENU SMJERA  
SASH INVERSION PROFILE

W=709 gr/m

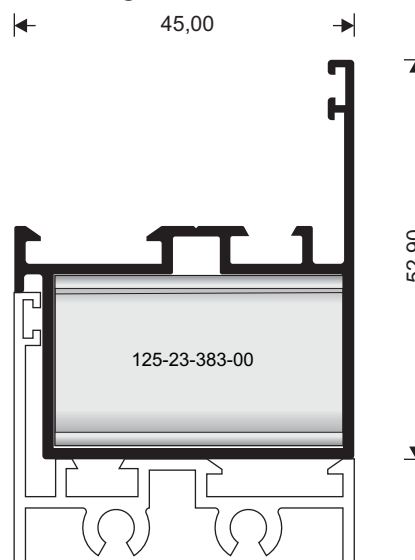

**UPOZORENJE!**  
UPOTREBLJAVA SE SAMO SA RAVNIM "T" PREČKAMA  
**CAUTION !**  
USED ONLY WITH FLAT "T" PROFILES

**M 9324**

W=242 gr/m

PROFIL ZA SPAJANJE ŠTOKOVA  
PROFILE FOR FRAME COUPLING

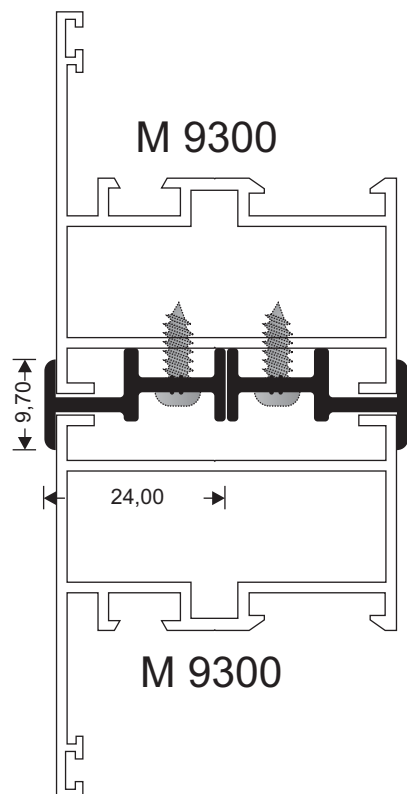

KORISTI SE ZA SPAJANJE (ŠTOK NA ŠTOK):  
FACILITATES THE COUPLING (FRAME TO FRAME):  
M9300-M9300 ; M9320-M9320 ; M9424-M9424

**M 9431**

W=561 gr/m

DODATNI PROFIL ZA DNO VRATA  
SUPPLEMENTARY PROFILE  
FOR MAIN ENTRANCE SASHES

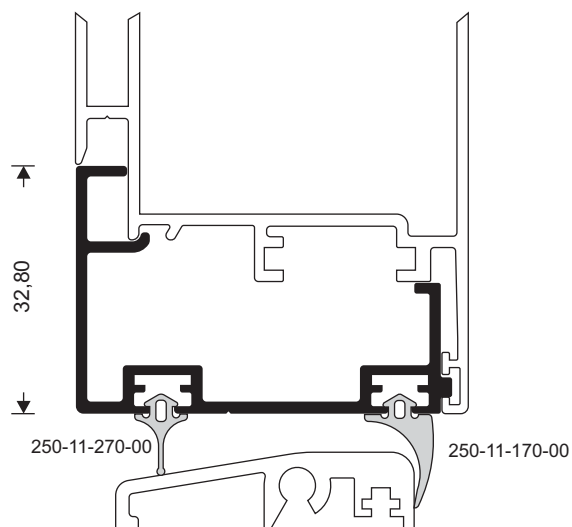

OZNAKA PVC ČEPOVA / PLASTIC ENDCAP CODE: 310-09-431-00

**M 9504**

W=929 gr/m

SREDNJA PREČKA  
ADJOINING PROFILE

ČEP ZA SREDNJU PREČKU / PLASTIC ENDCAP CODE: 300-09-304-00

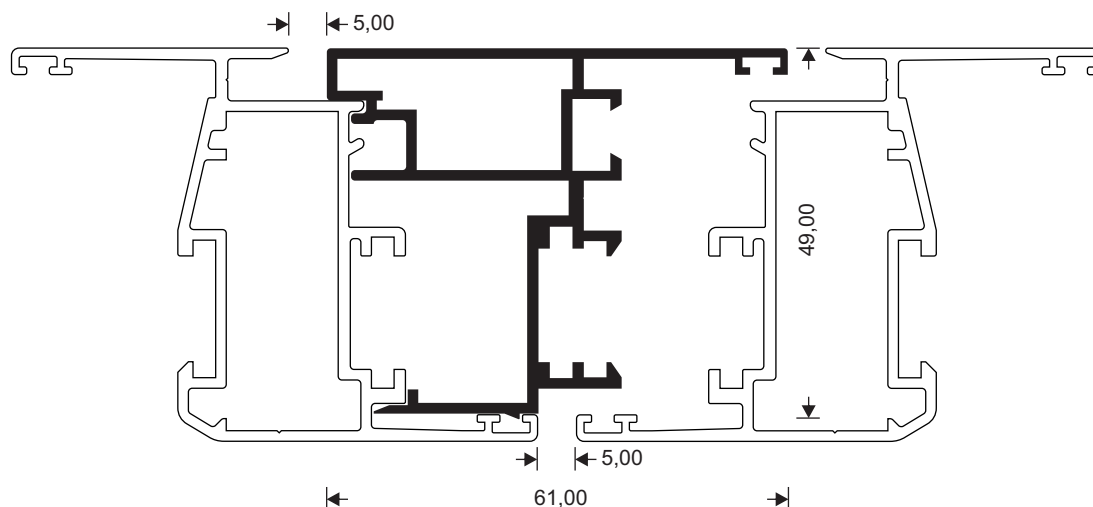

**M 9544**  
W=904 gr/m

SREDNJA PREČKA  
ADJOINING PROFILE

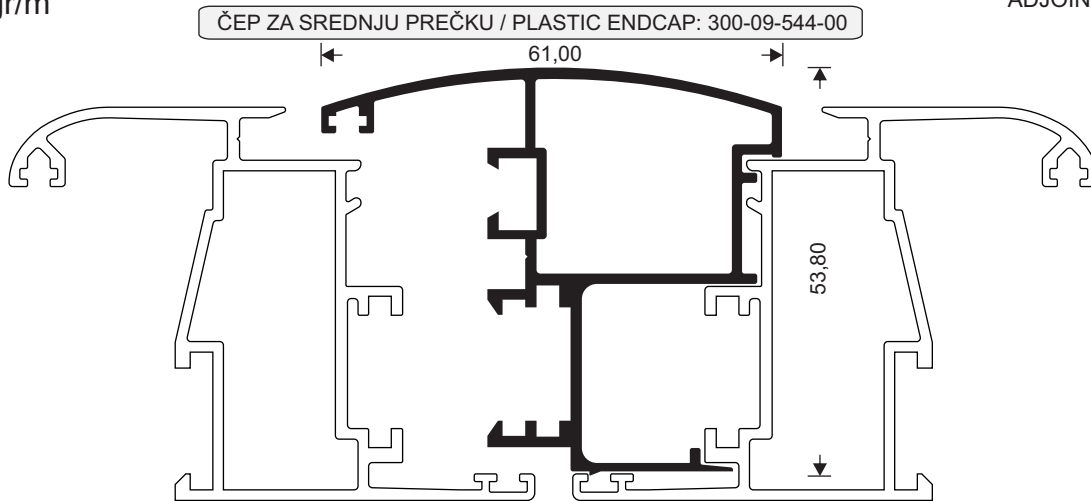

**M 11116**  
W=184 gr/m

OKAPNICA  
WATERCAP

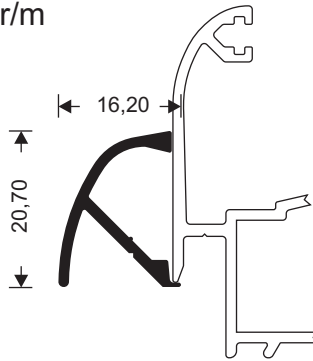

**M 9317**  
W=181 gr/m

OKAPNICA  
WATERCAP

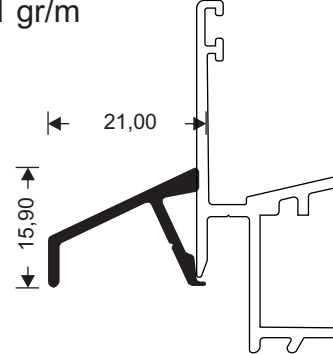

OZNAKA PVC ČEPOVA / PLASTIC ENDCAP CODE: 310-11-116-00

OZNAKA PVC ČEPOVA / PLASTIC ENDCAP CODE: 310-09-317-00

**M 9375** UGAO 90°  
W=834 gr/m SUPPLEMENTARY PROFILE FOR 90°

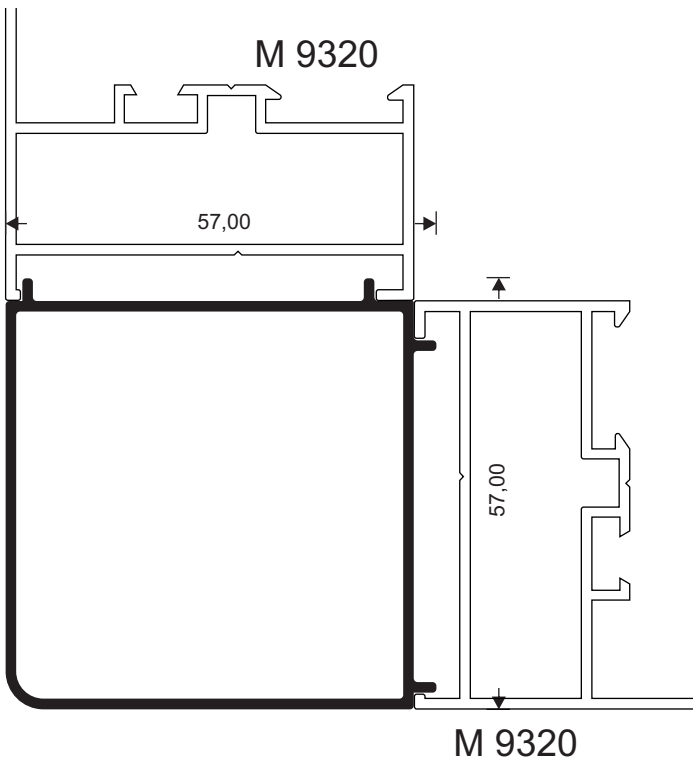

**M 9376** UGAO 135°  
W=595 gr/m SUPPLEMENTARY PROFILE FOR 135°

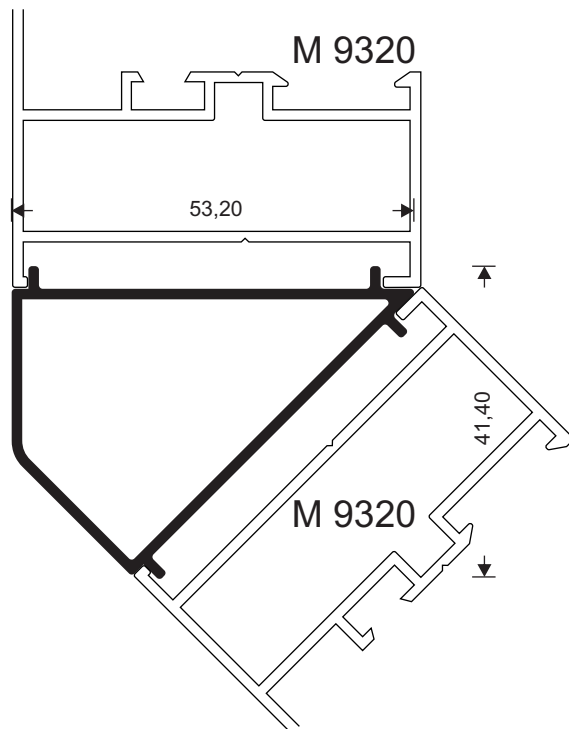

UPOZORENJE: PROFILI SE KORISTE ISKLJUČIVO SA ŠTOKOM M9320  
CAUTION: THE PROFILE IS DESIGNED FOR ANGULAR CONSTRUCTIONS WITH FRAME M9320 ONLY

**M 9533**

W=1924 gr/m

PARAPET  
KICKPLATE

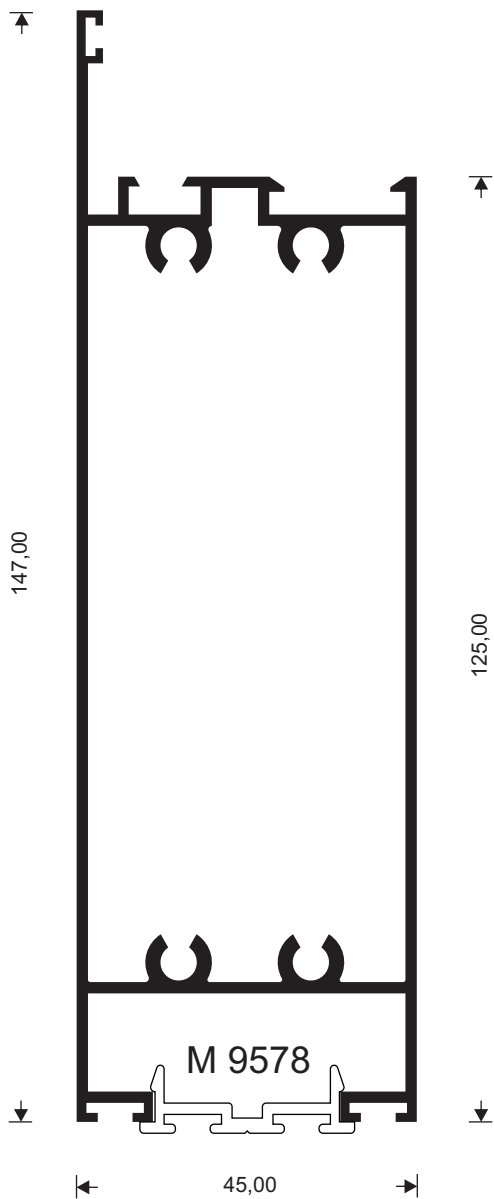

**T 35**

W=871 gr/m

CIJEV ZA FLEKSIBILNI UGAO  
COLUMN FOR VARIABLE  
ANGULAR CONSTRUCTIONS

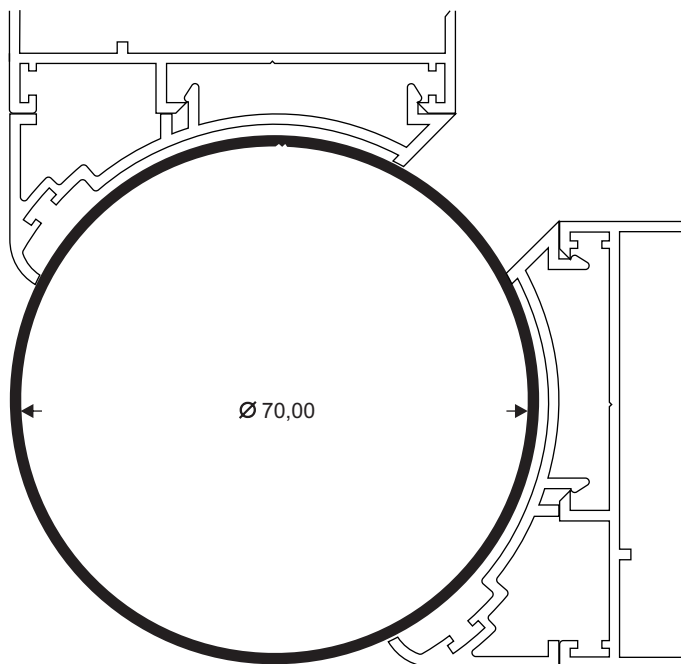

**M 9427**

W=429 gr/m

LAJRNA ZA FLEKSIBILNI UGAO  
ADJ. PROFILE FOR VARIABLE  
ANGULAR CONSTRUCTIONS  
WITH FRAME M9510

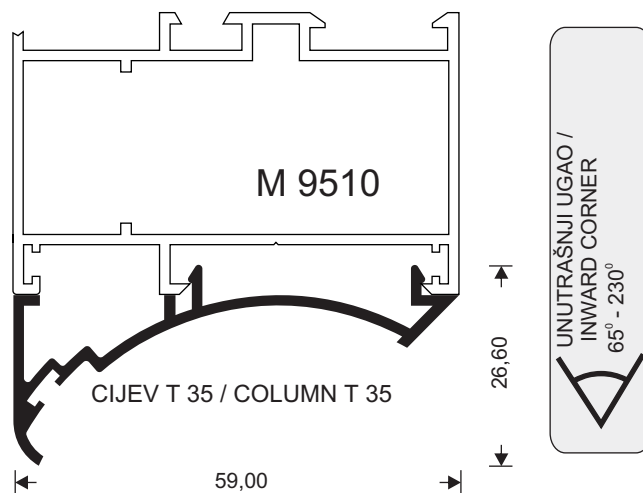

**M 9578**

W=1924 gr/m

NOSAČ GUME ZA DNO VRATA  
SUPPLEMENTARY SEALING PROFILE  
FOR KICKPLATES

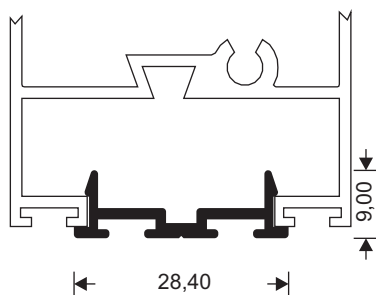

**M 9316**

W=136 gr/m

POTISNA LETVA  
ROD

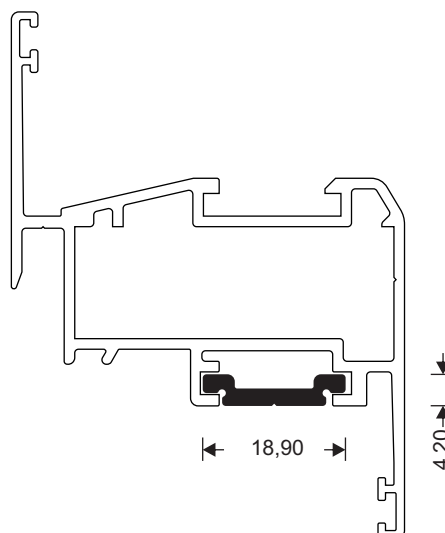

**M 9576**  
W=956 gr/m

KRILO ZA "SALON" VRATA  
SASH FOR "SALOON" DOORS

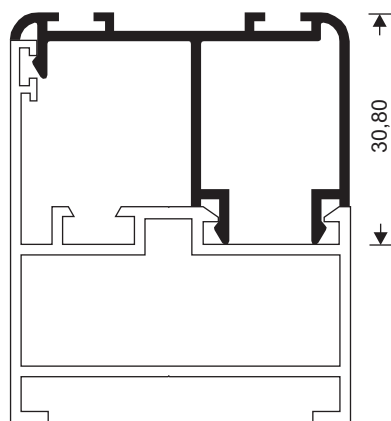
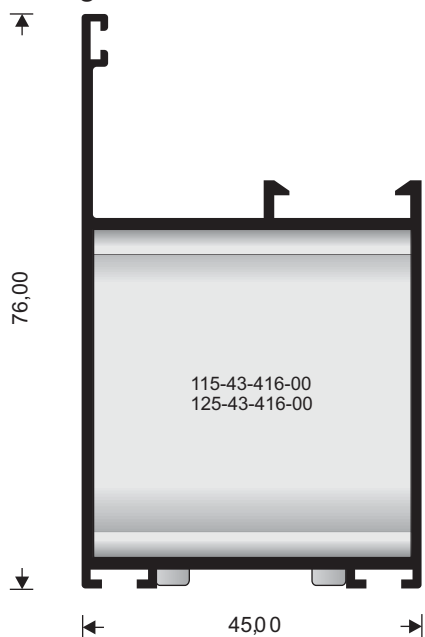

**M 9419**  
W=397 gr/m

DEKORATIVNI PROFIL  
DECORATIVE ARMATURE

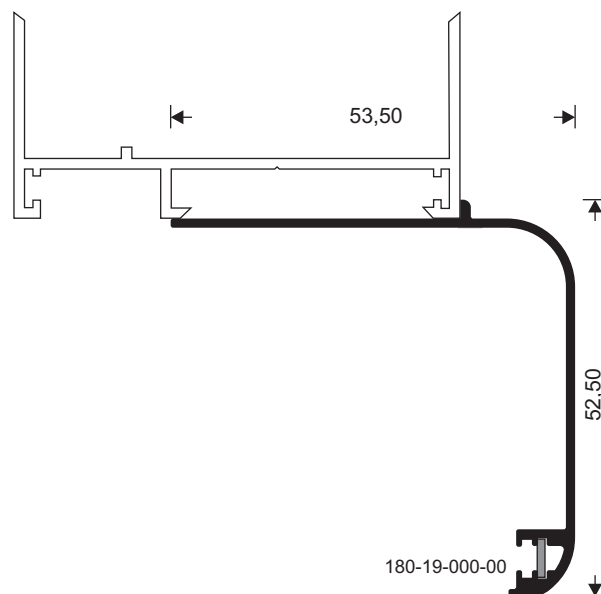

**2266**  
W = 1569 gr/m

OJAČANJE ZA BHT4645  
SUPPLEMENTARY PROFILE BHT4645

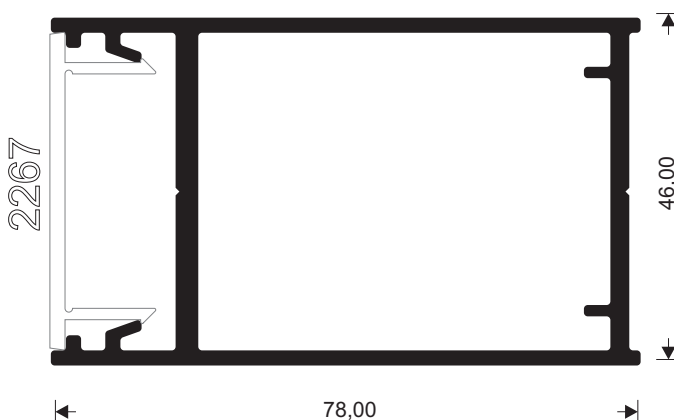

**M 9322**  
W=479 gr/m

DODATAK ZA ŠTOK ZA "SALON" VRATA  
FRAME ADDITION FOR "SALOON" DOORS

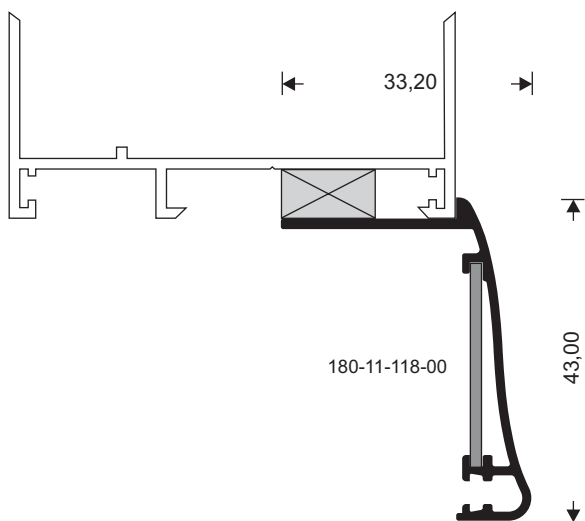

**M 11118**

DEKORATIVNI PROFIL  
DECORATIVE ARMATURE

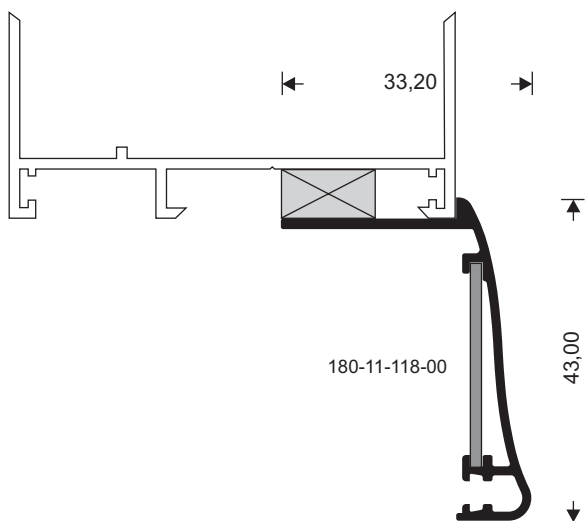

**2267**  
W = 318 gr/m

POKLOPAC ZA 2266  
CAP FOR 2266

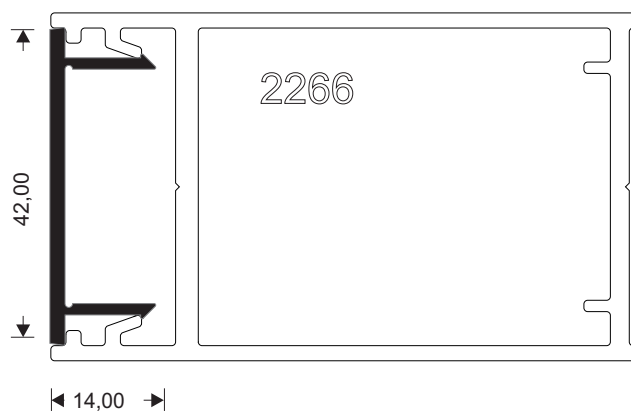

### M 11453

LAJSNA ZA STAKLO  
GLAZING BEAD

W=328 gr/m

← 16 → → 26 →

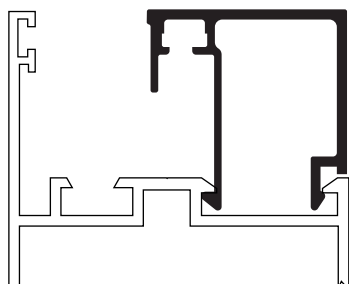

DEBLJINA ISPUNE / GLAZING TICKNESS: 8mm

### M 11463

LAJSNA ZA STAKLO  
GLAZING BEAD

W=311 gr/m

← 16 → → 26 →

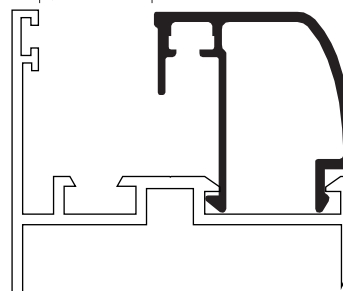

DEBLJINA ISPUNE / GLAZING TICKNESS: 8mm

### M 11454

LAJSNA ZA STAKLO  
GLAZING BEAD

W=350 gr/m

← 12 → → 30 →

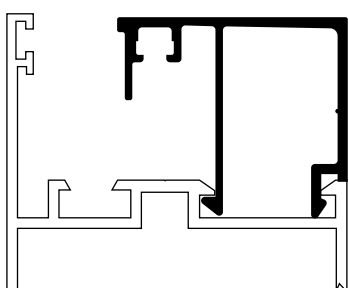

DEBLJINA ISPUNE / GLAZING TICKNESS: 4mm

### M 11464

LAJSNA ZA STAKLO  
GLAZING BEAD

W=332 gr/m

← 12 → → 30 →

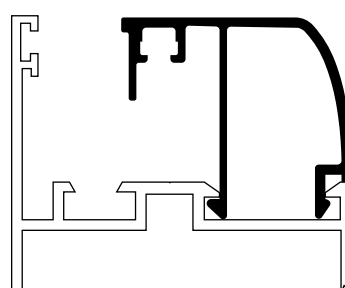

DEBLJINA ISPUNE / GLAZING TICKNESS: 4mm

### M 11451

LAJSNA ZA STAKLO  
GLAZING BEAD

W = 307 gr/m

← 24 → → 18 →

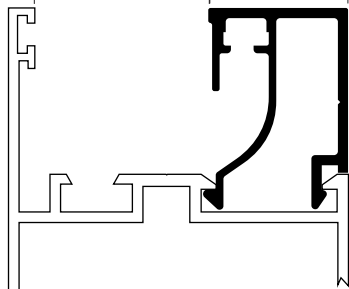

DEBLJINA ISPUNE / GLAZING TICKNESS: 16mm

### M 9565

LAJSNA ZA STAKLO  
GLAZING BEAD

W=254 gr/m

← 32,50 → → 9,5 →

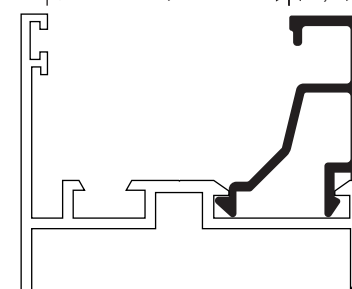

DEBLJINA ISPUNE / GLAZING TICKNESS: 24mm

### M 11461

LAJSNA ZA STAKLO  
GLAZING BEAD

W=286 gr/m

← 24 → → 18 →

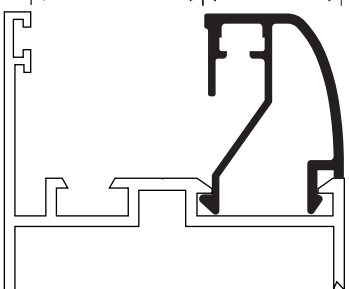

DEBLJINA ISPUNE / GLAZING TICKNESS: 16mm

### M 11455

LAJSNA ZA ZATVARANJE ŠTOKA  
GLAZING BEAD

W=366 gr/m

← 42,00 →

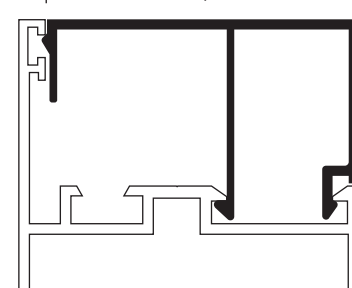

DEBLJINA ISPUNE / GLAZING TICKNESS: 0mm

**M 11462**

LAJSNA ZA STAKLO  
GLAZING BEAD

W = 297 gr/m

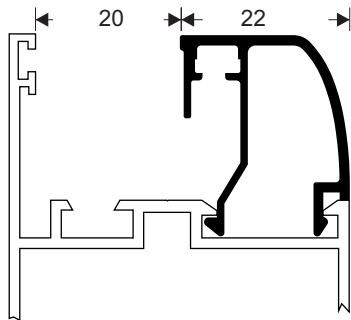

DEBLJINA ISPUNE / GLAZING THICKNESS: 12mm

**M 11452**

LAJSNA ZA STAKLO  
GLAZING BEAD

W = 313 gr/m

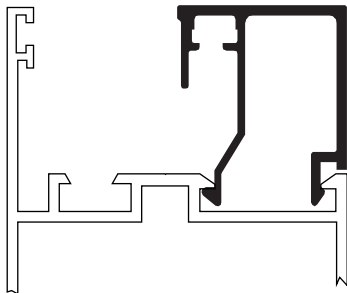

DEBLJINA ISPUNE / GLAZING THICKNESS: 12mm

**M 9312**

LAJSNA ZA STAKLO  
GLAZING BEAD

W=241 gr/m

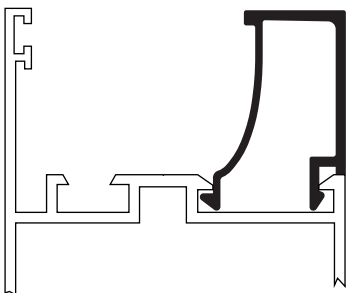

DEBLJINA ISPUNE / GLAZING THICKNESS: 20mm

**M 946**

LAJSNA ZA STAKLO  
GLAZING BEAD

W=232 gr/m

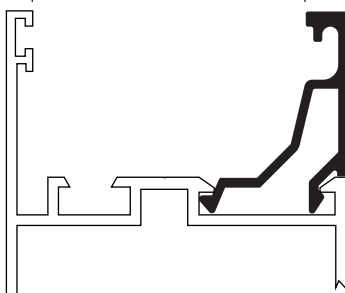

DEBLJINA ISPUNE / GLAZING THICKNESS: 28mm



# Presjeci Sections

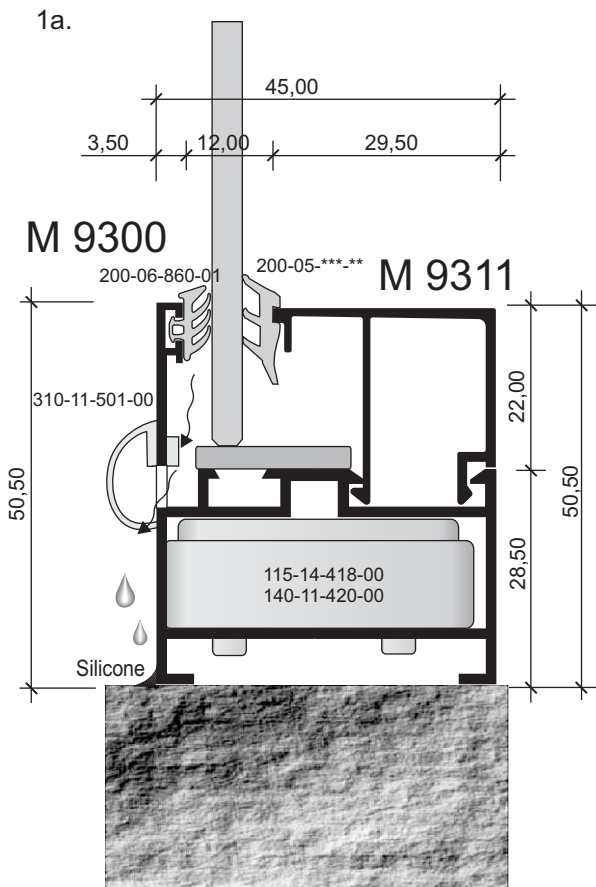
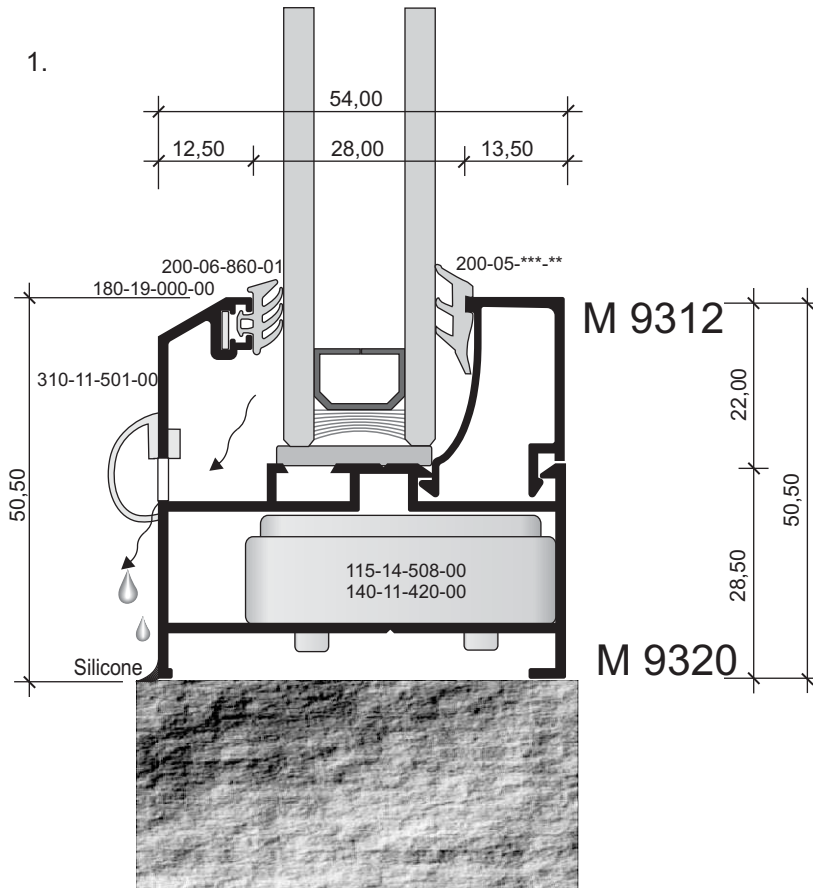
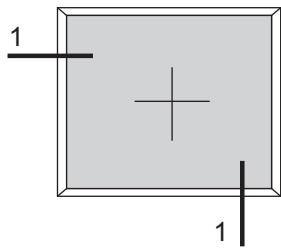

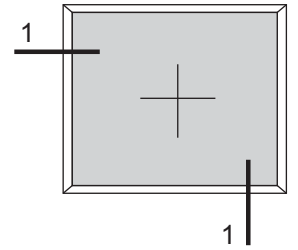
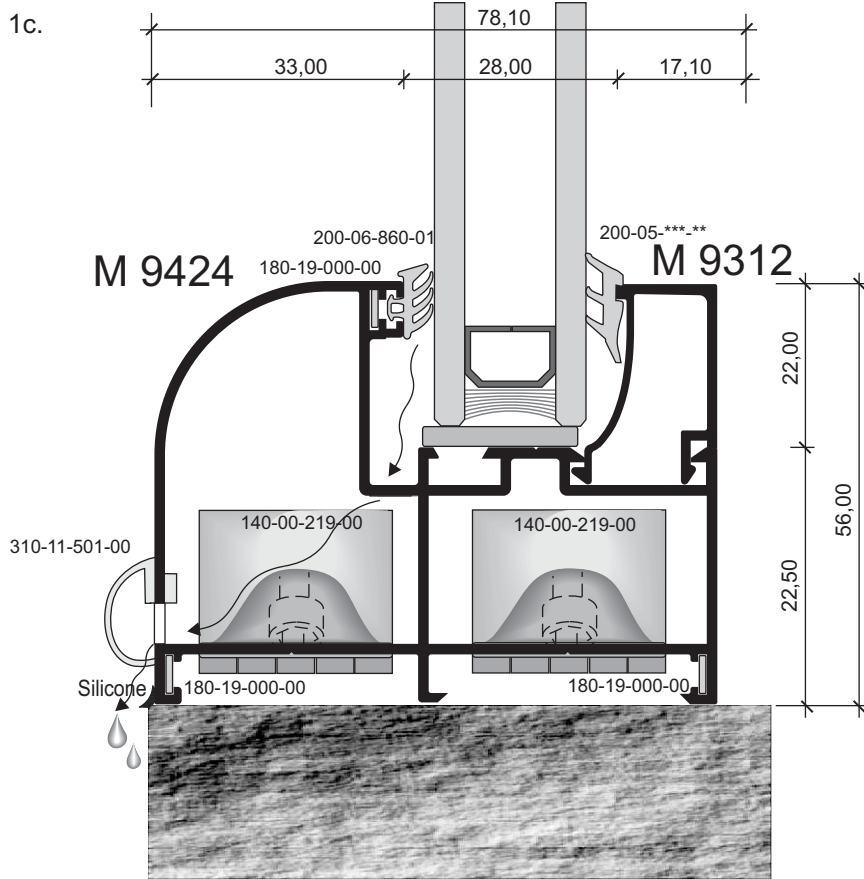

3.

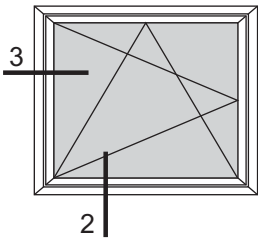
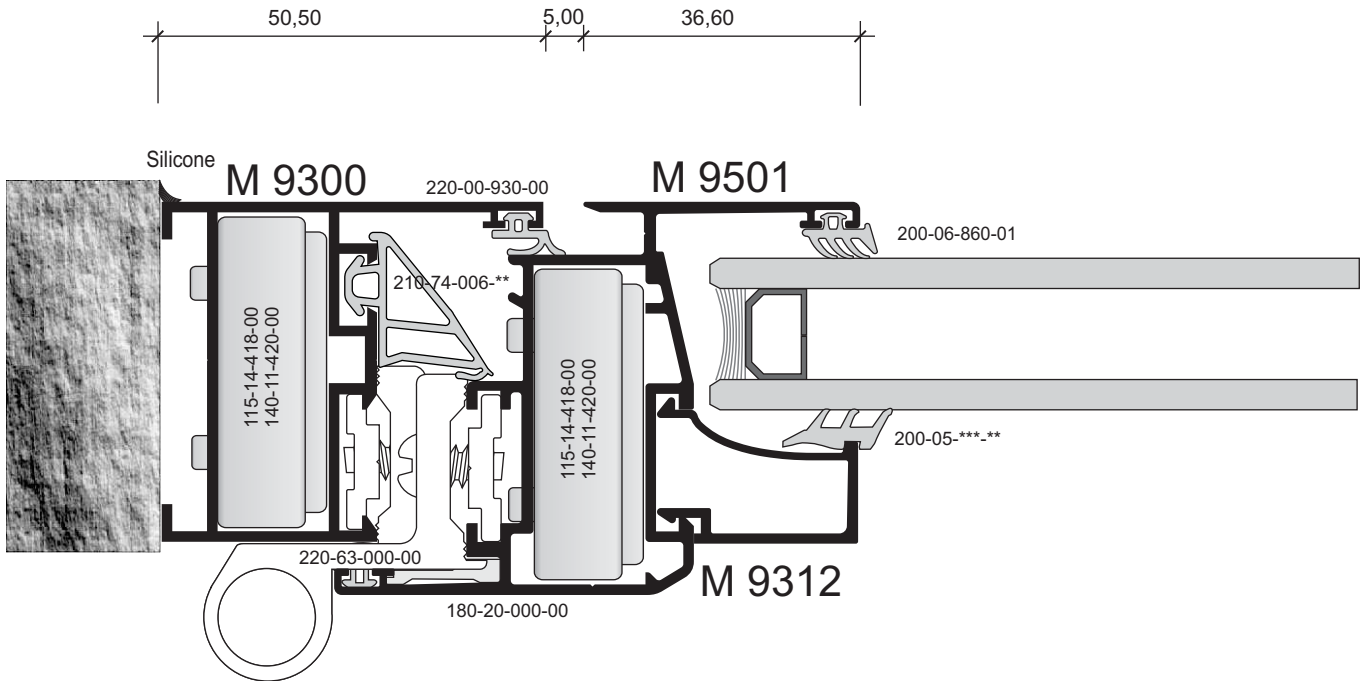

2.

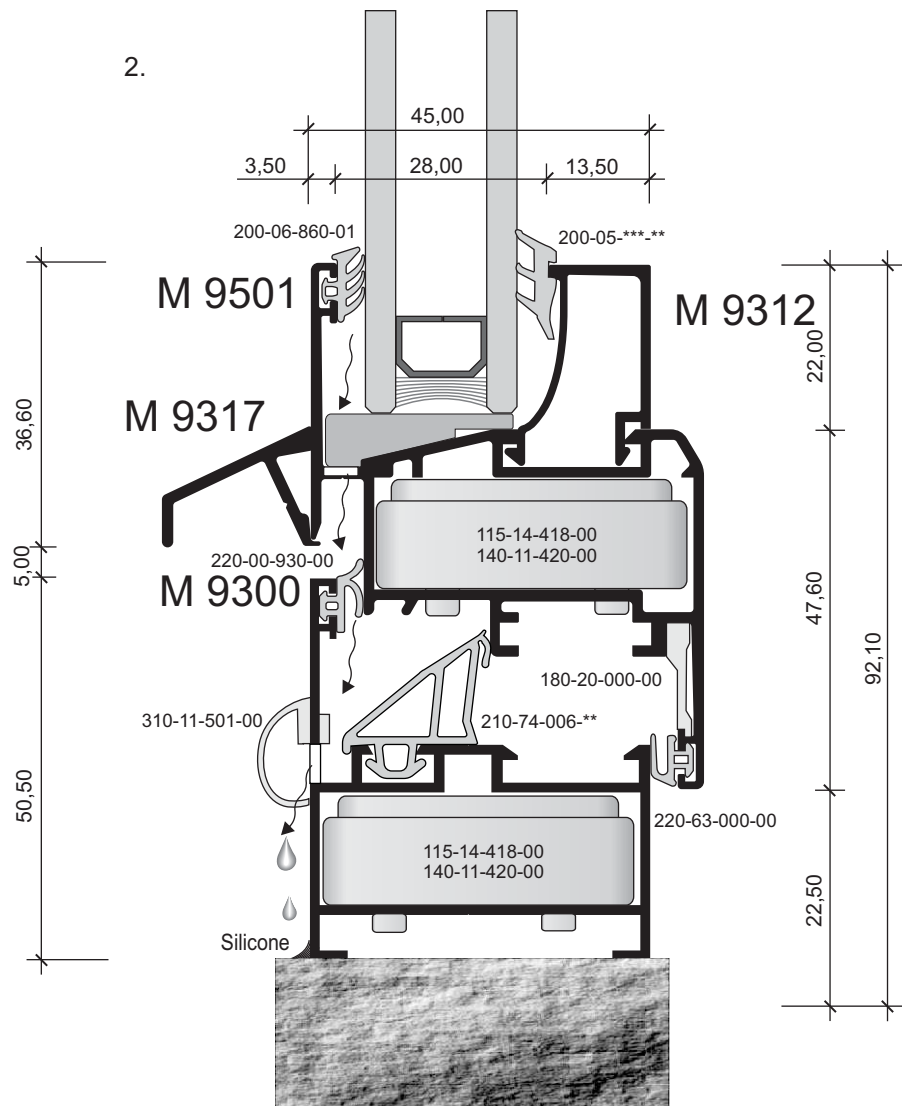

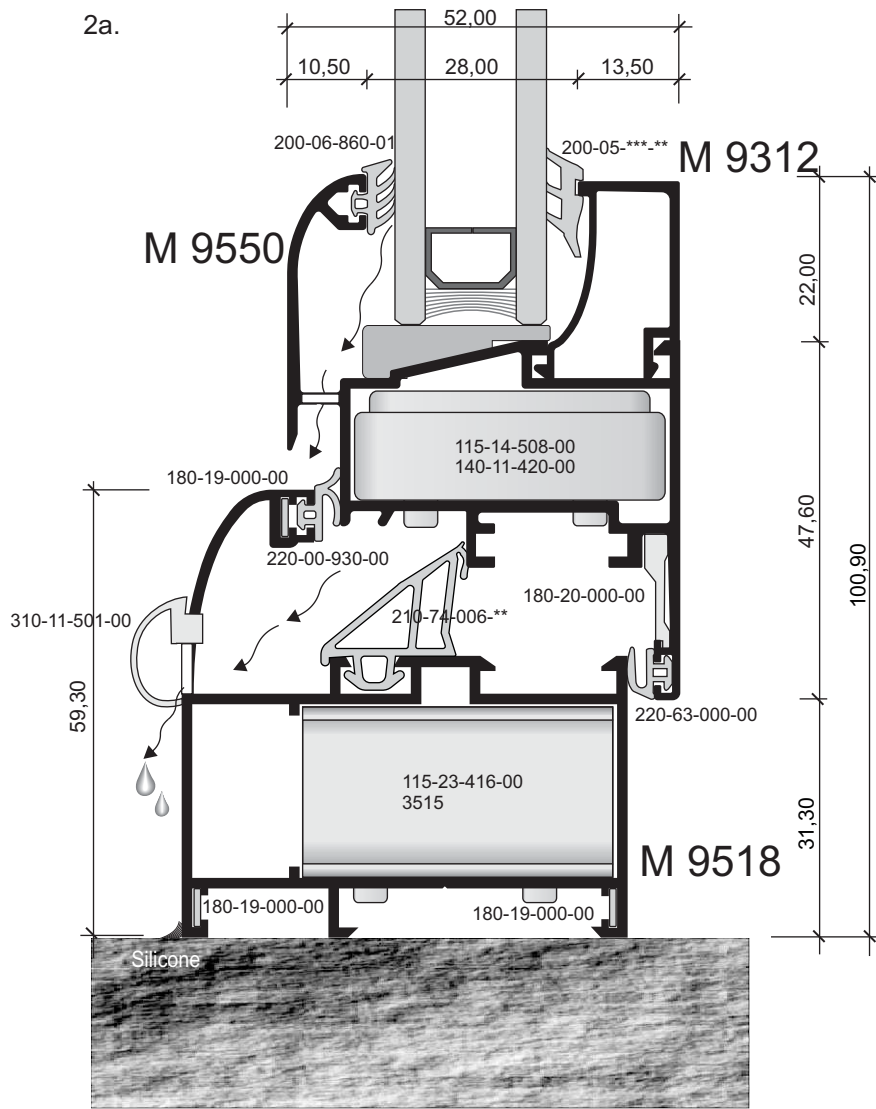

3a.

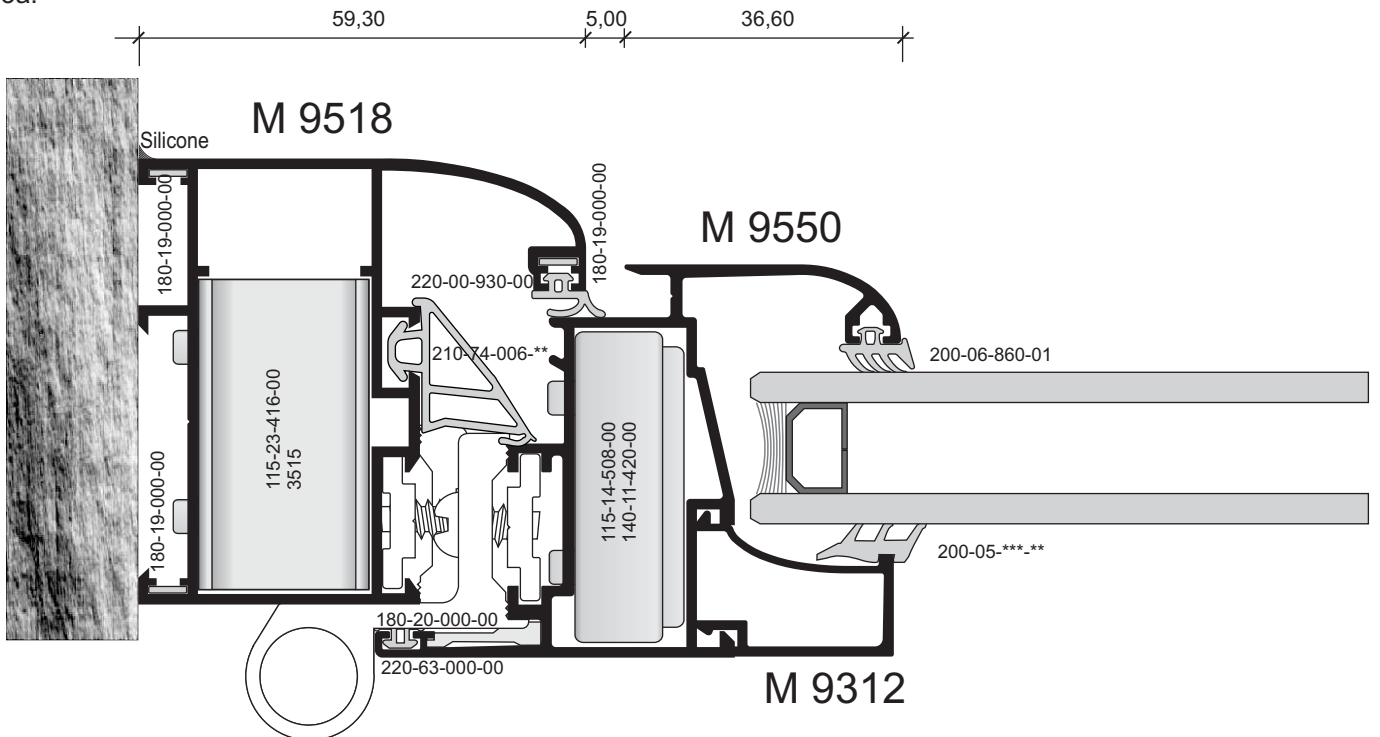

2c.

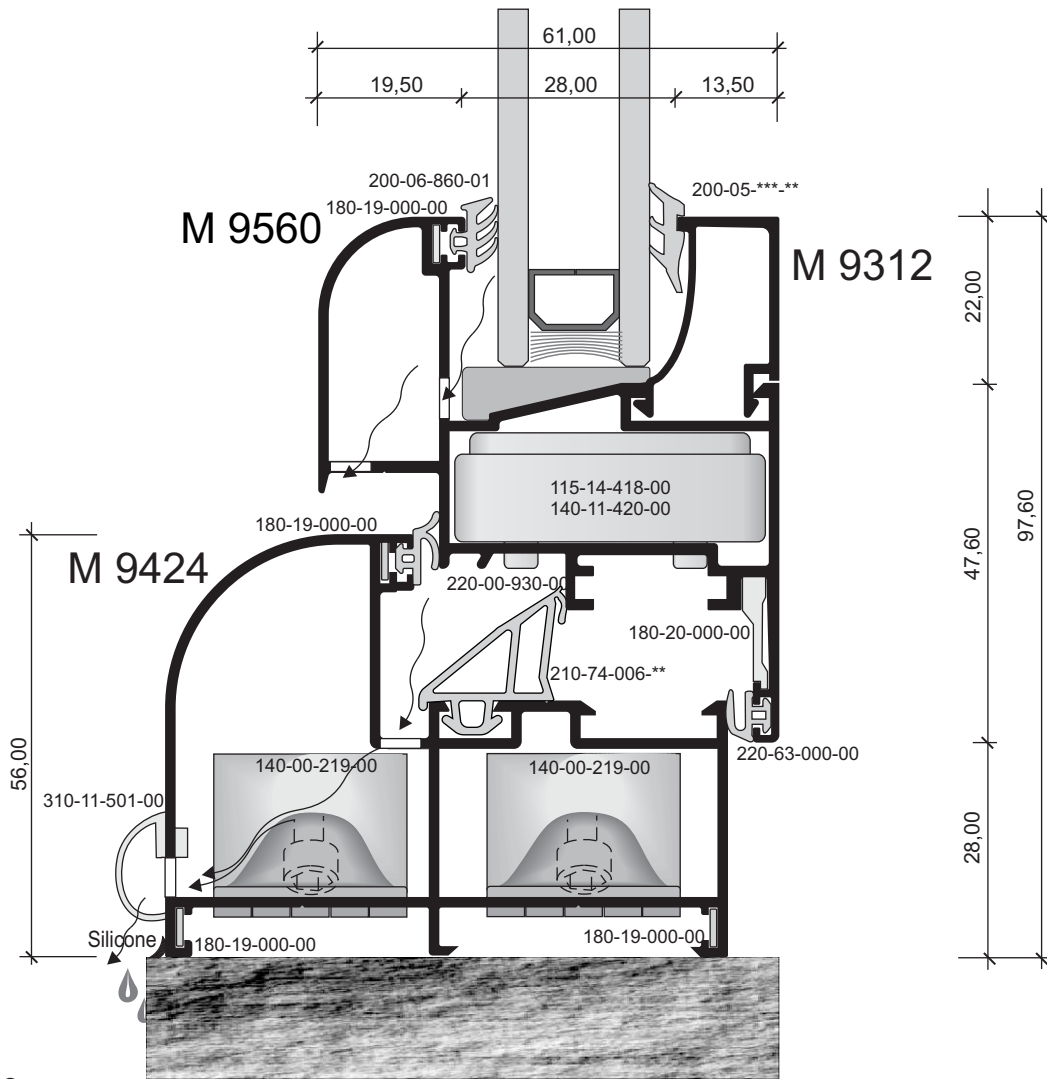

3c.

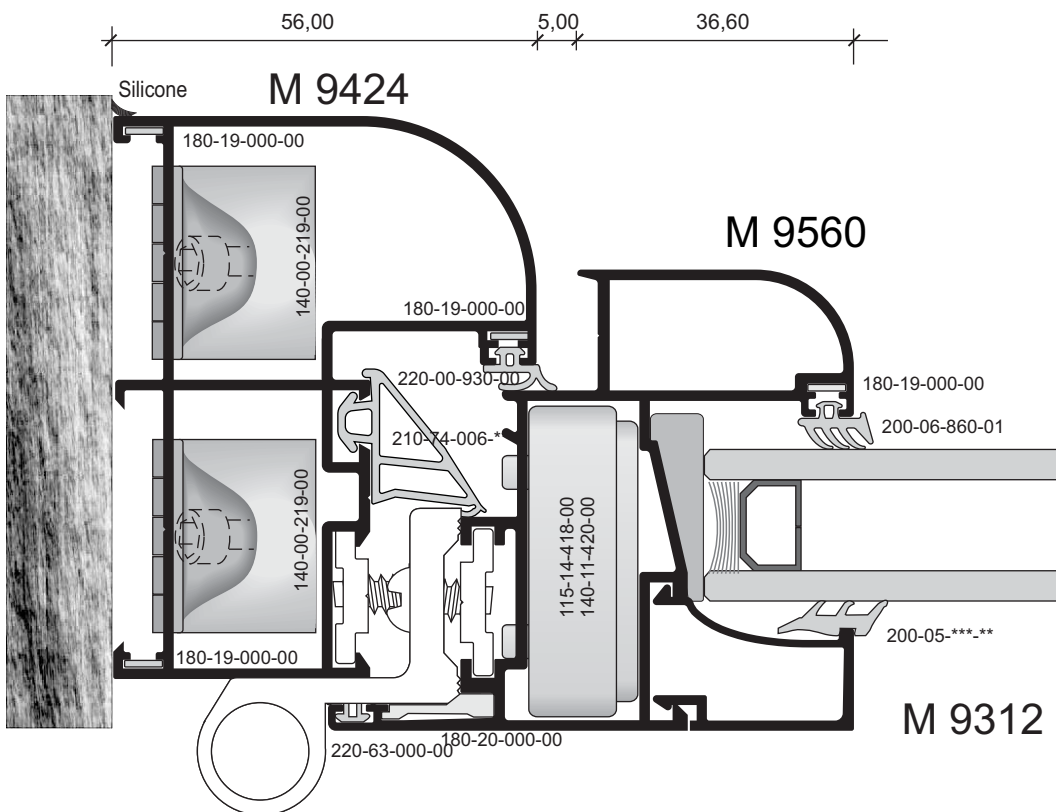

4a.

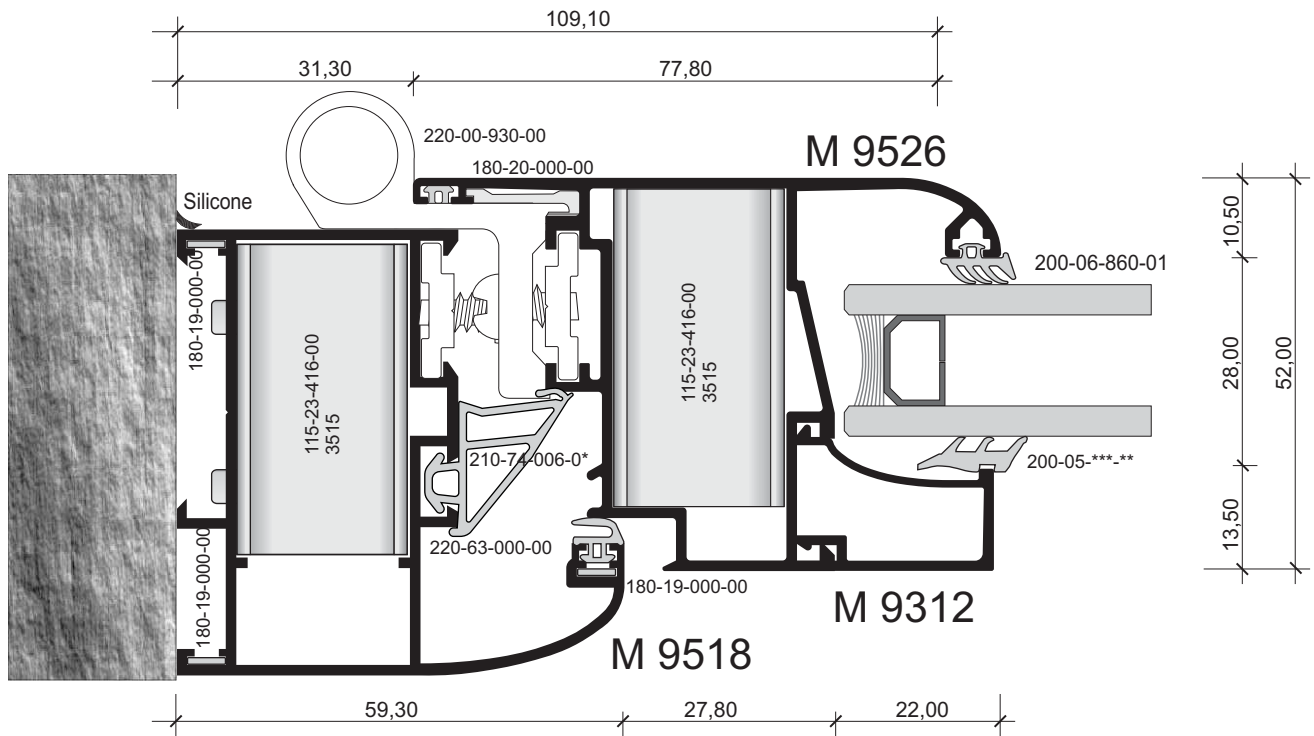

5a.

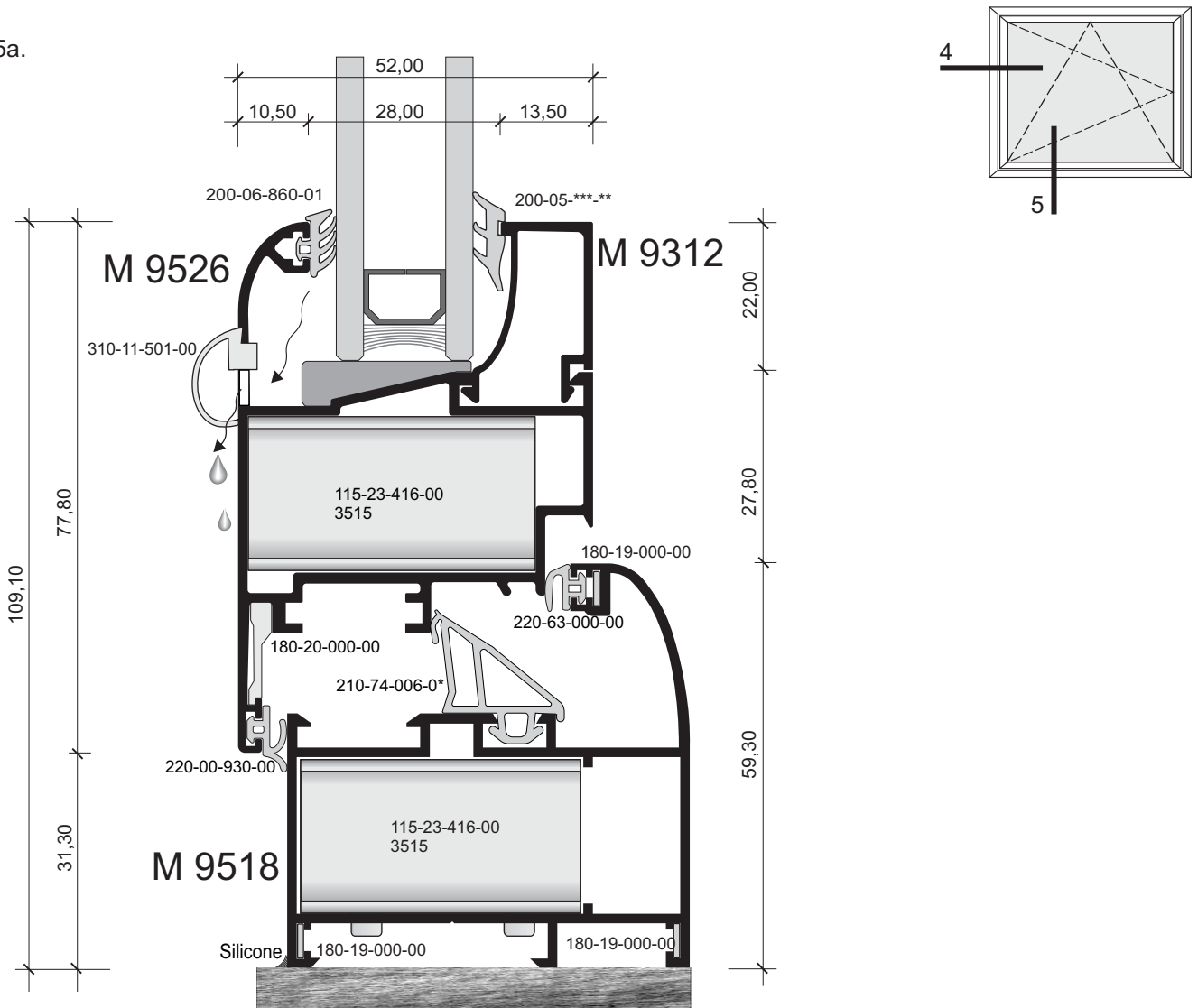

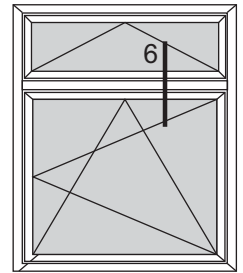
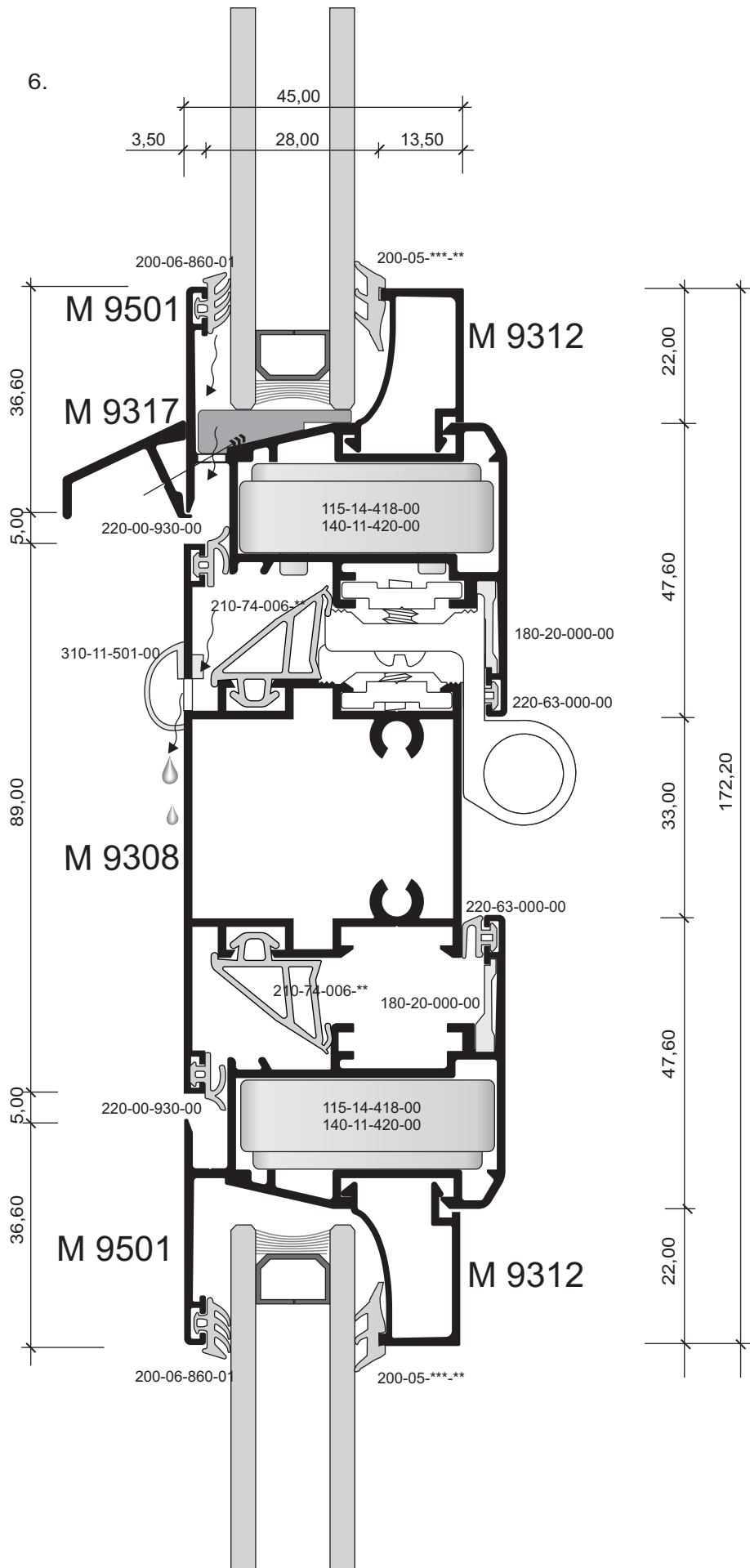

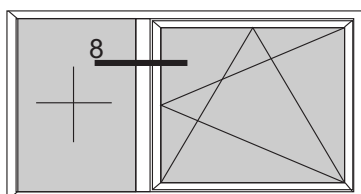
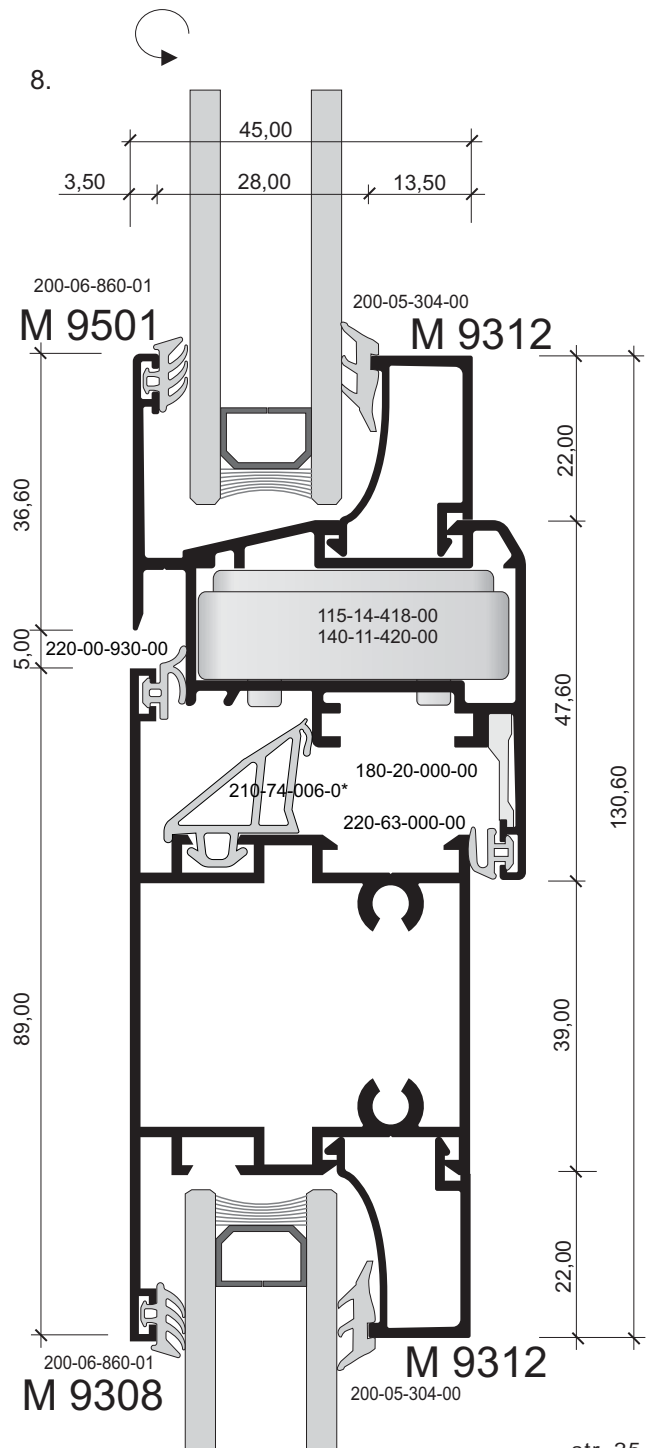
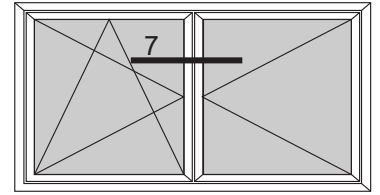
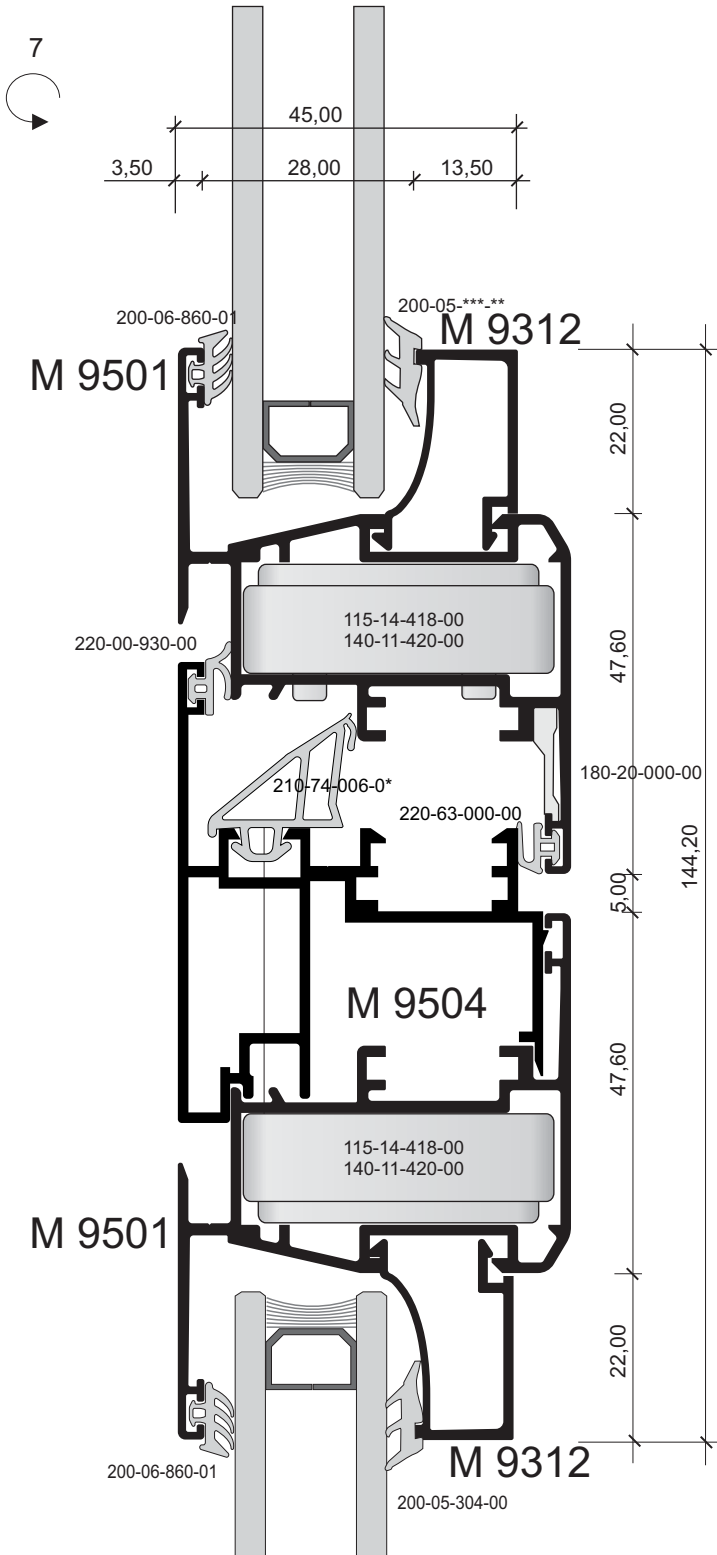

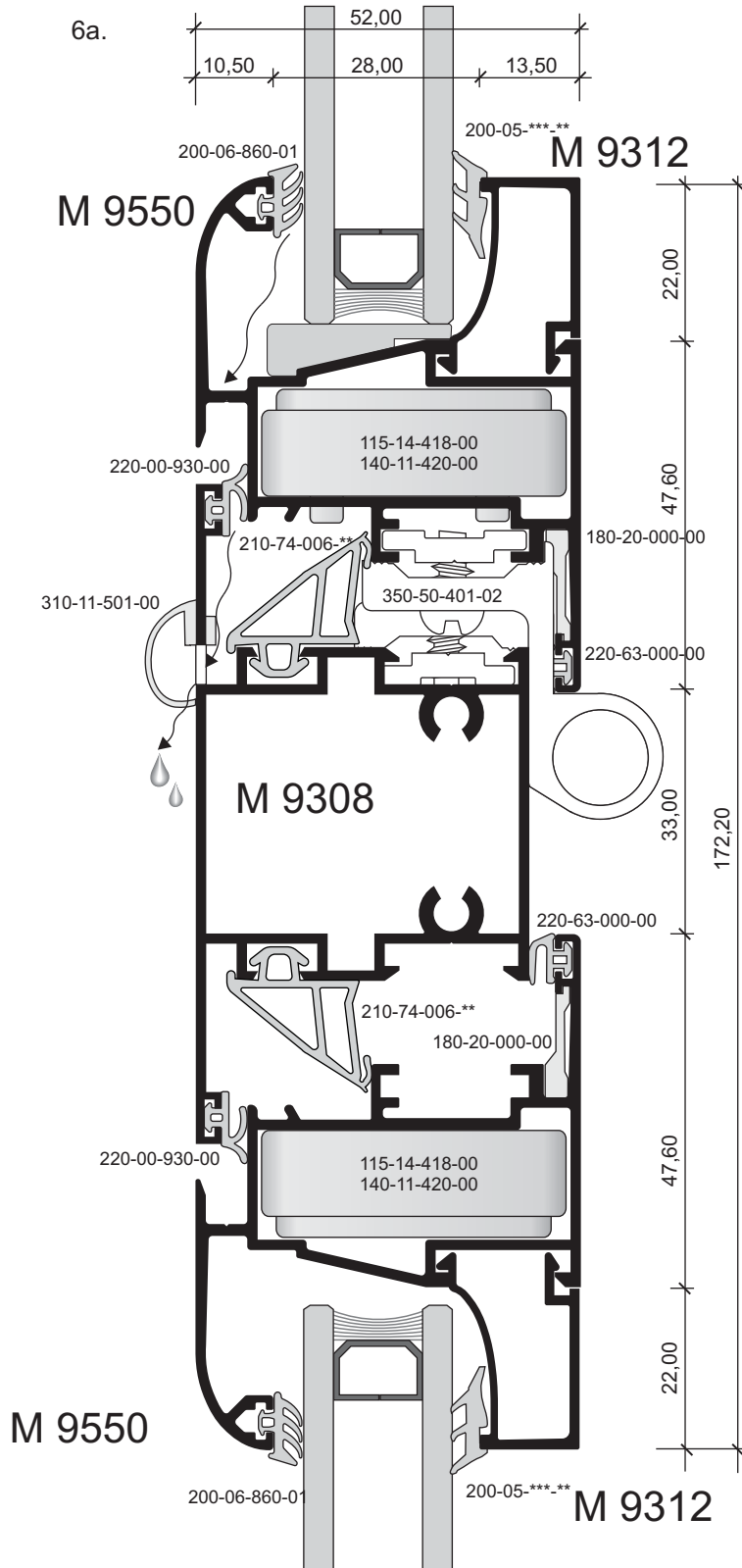
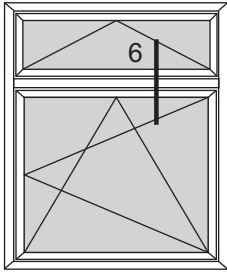

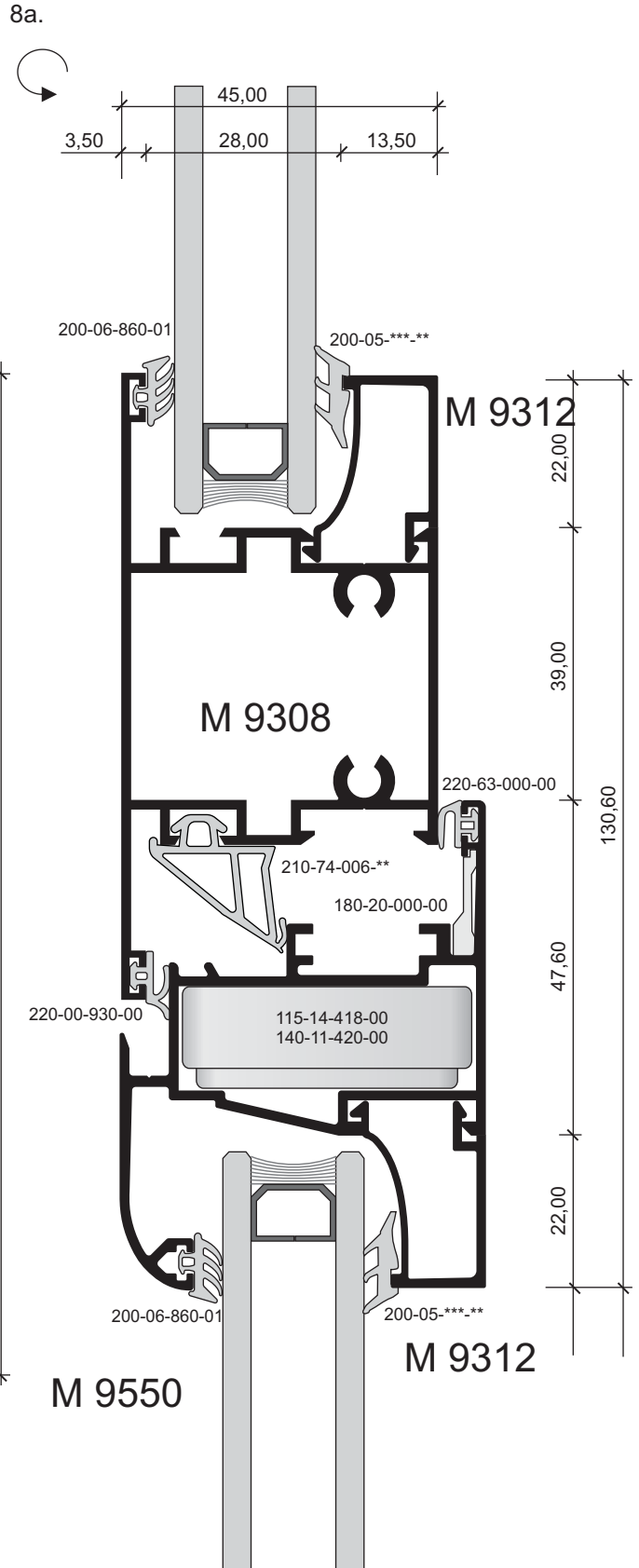
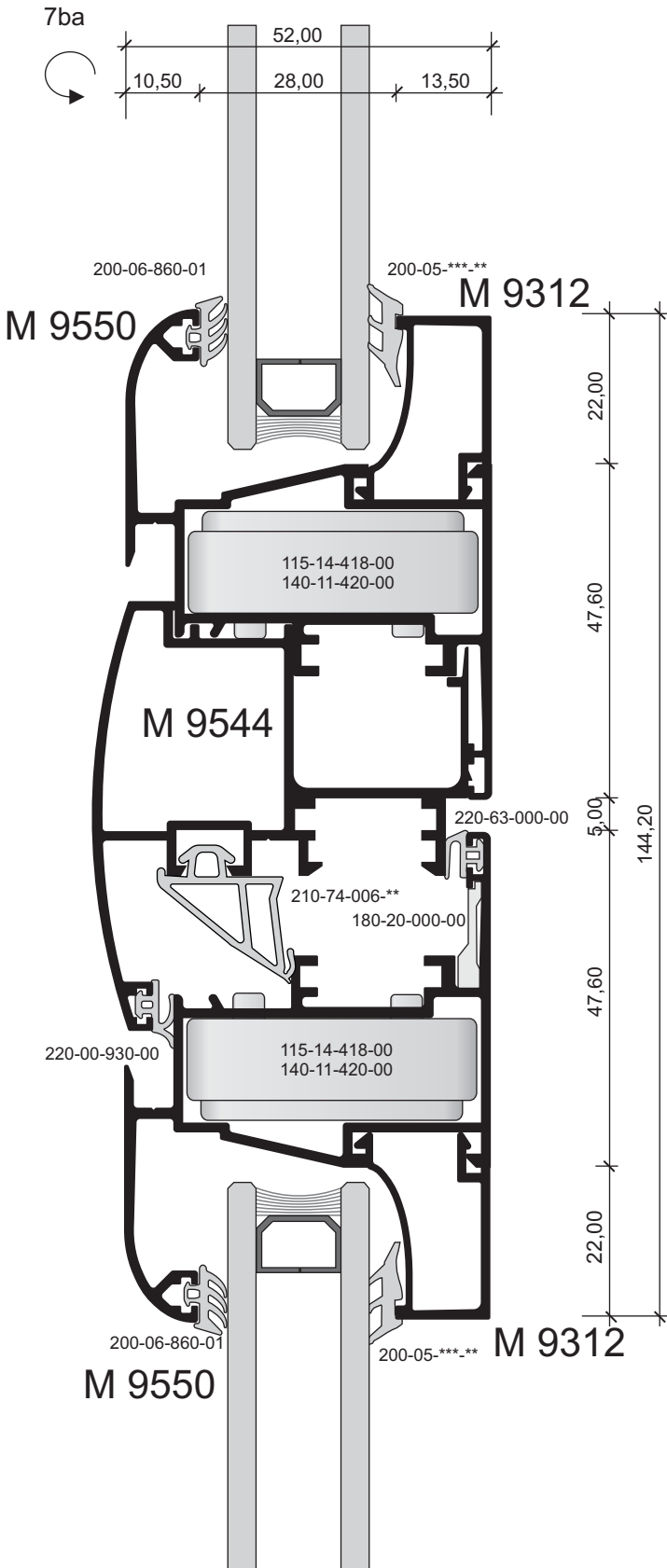
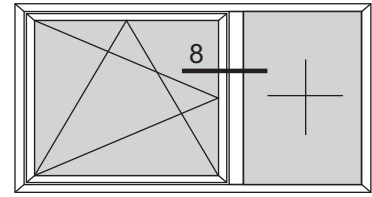
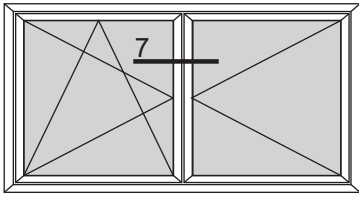

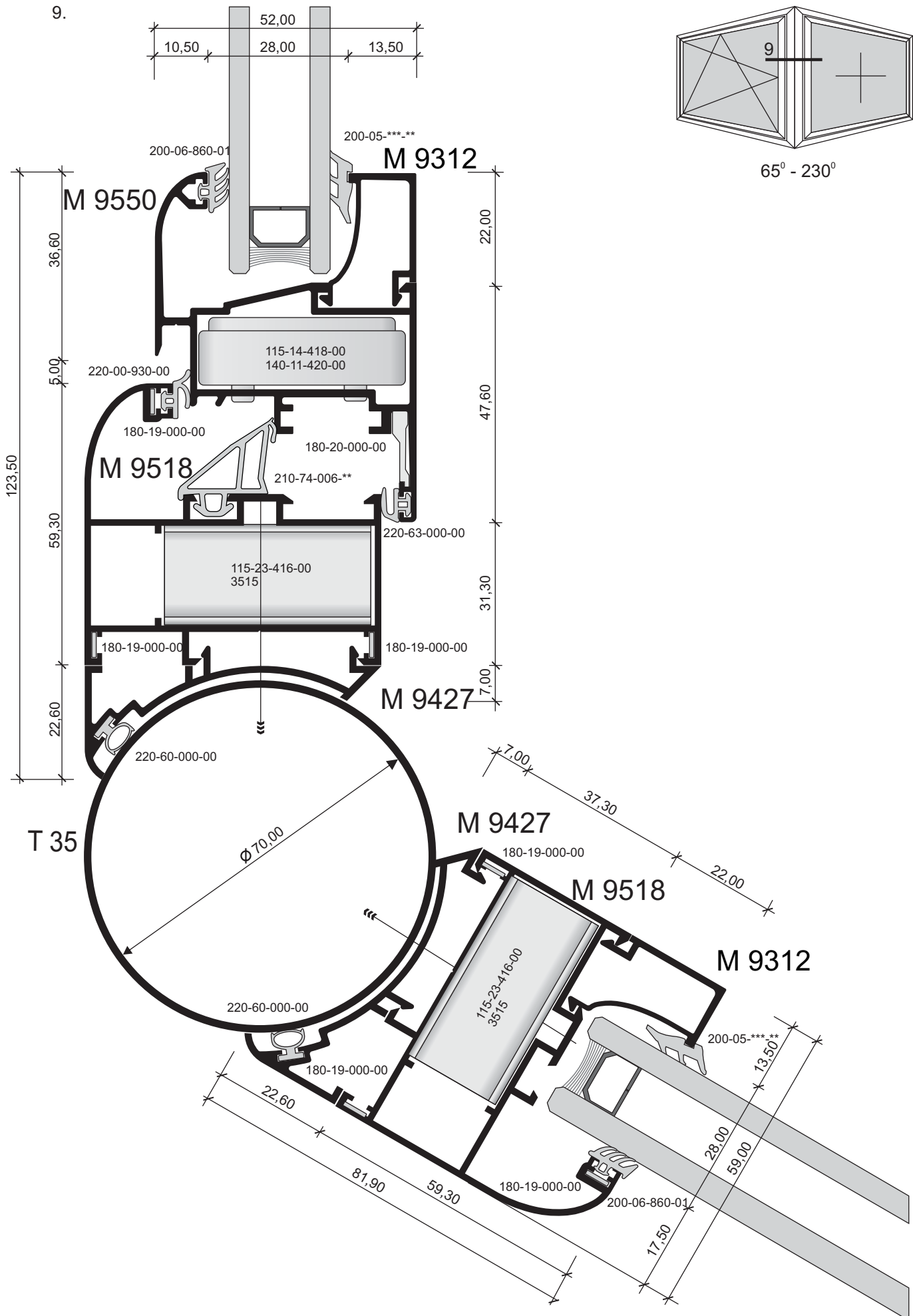

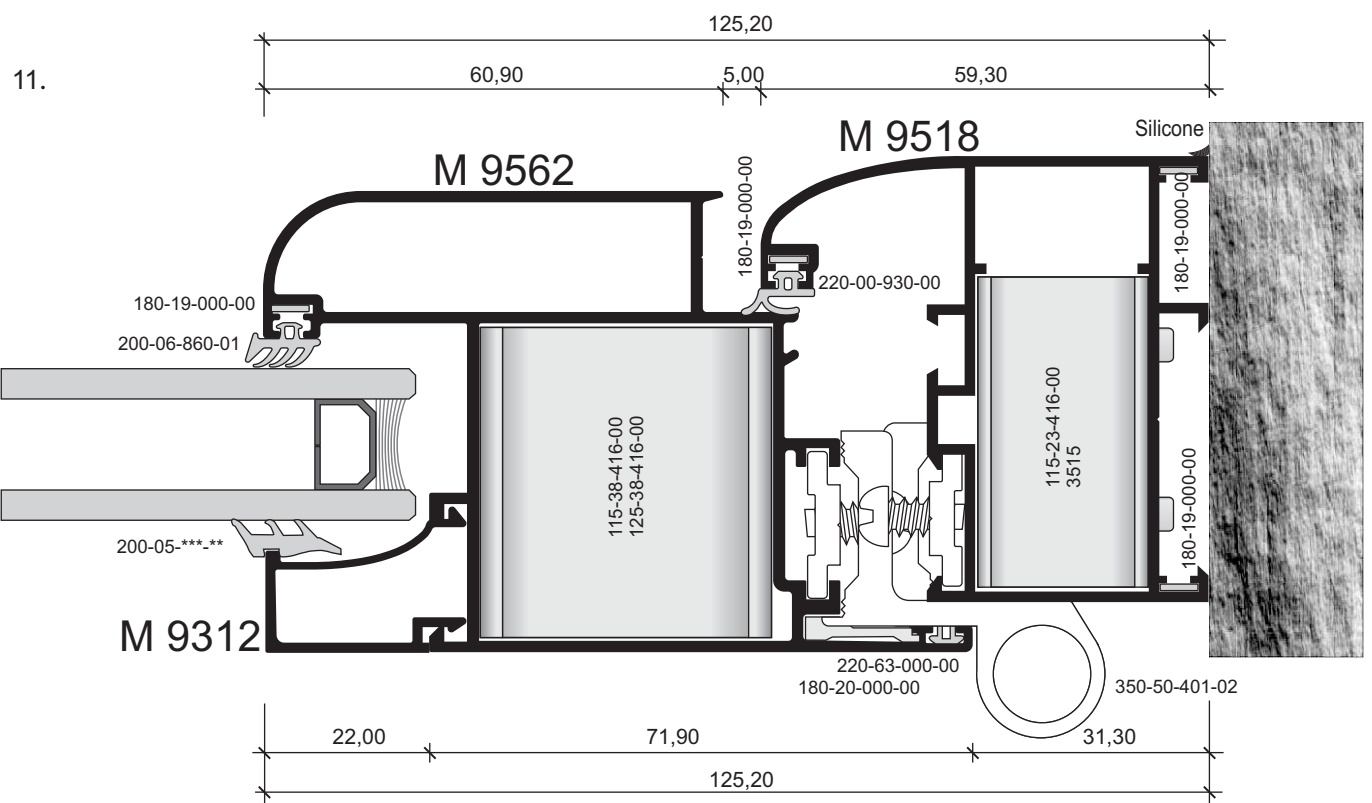
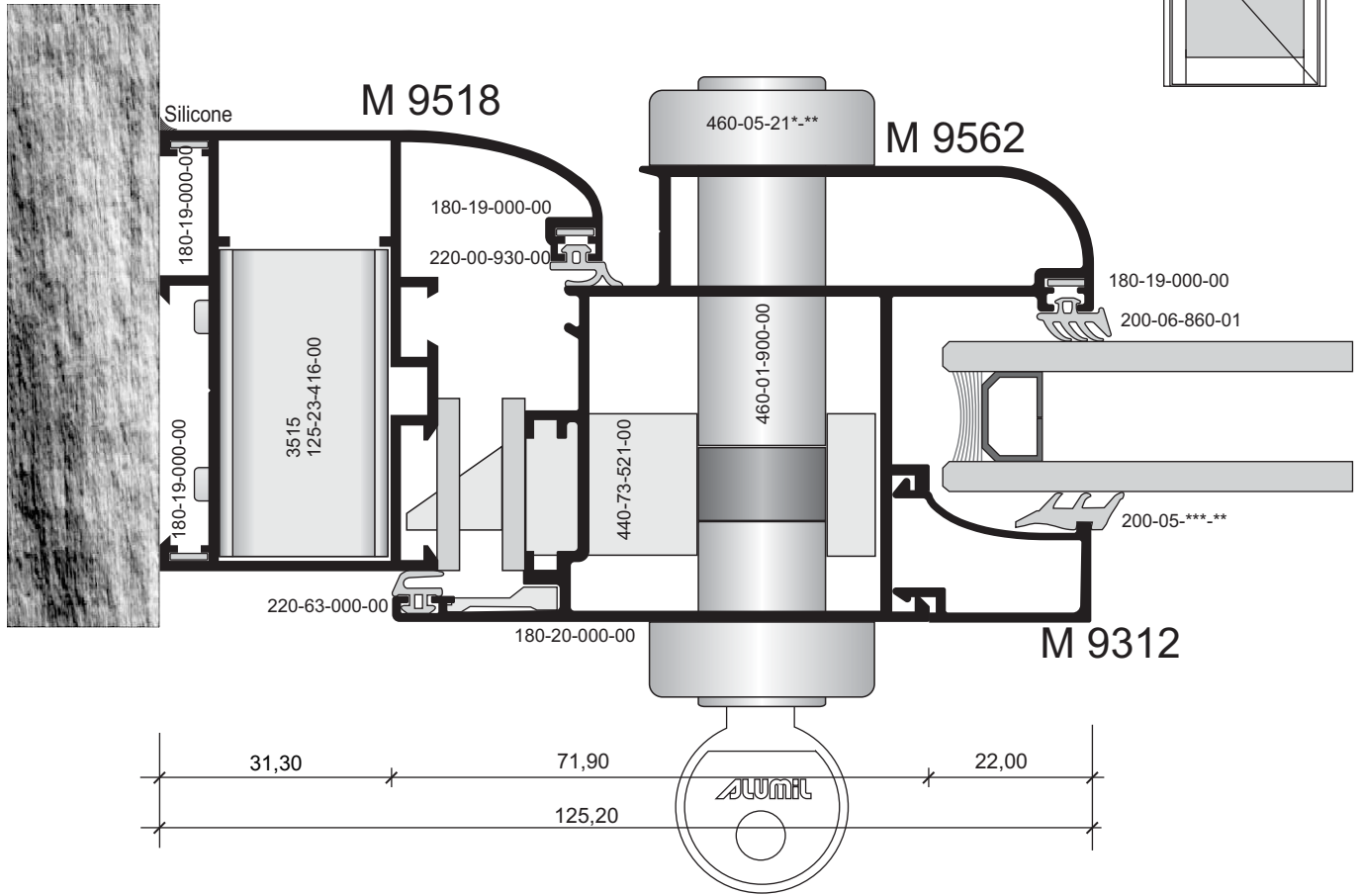
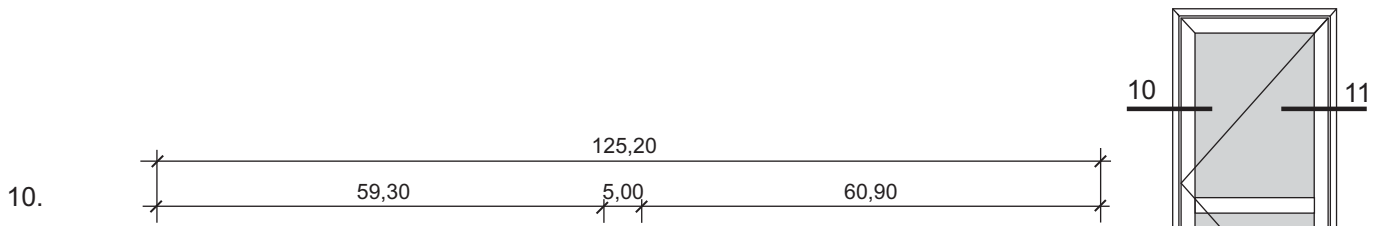

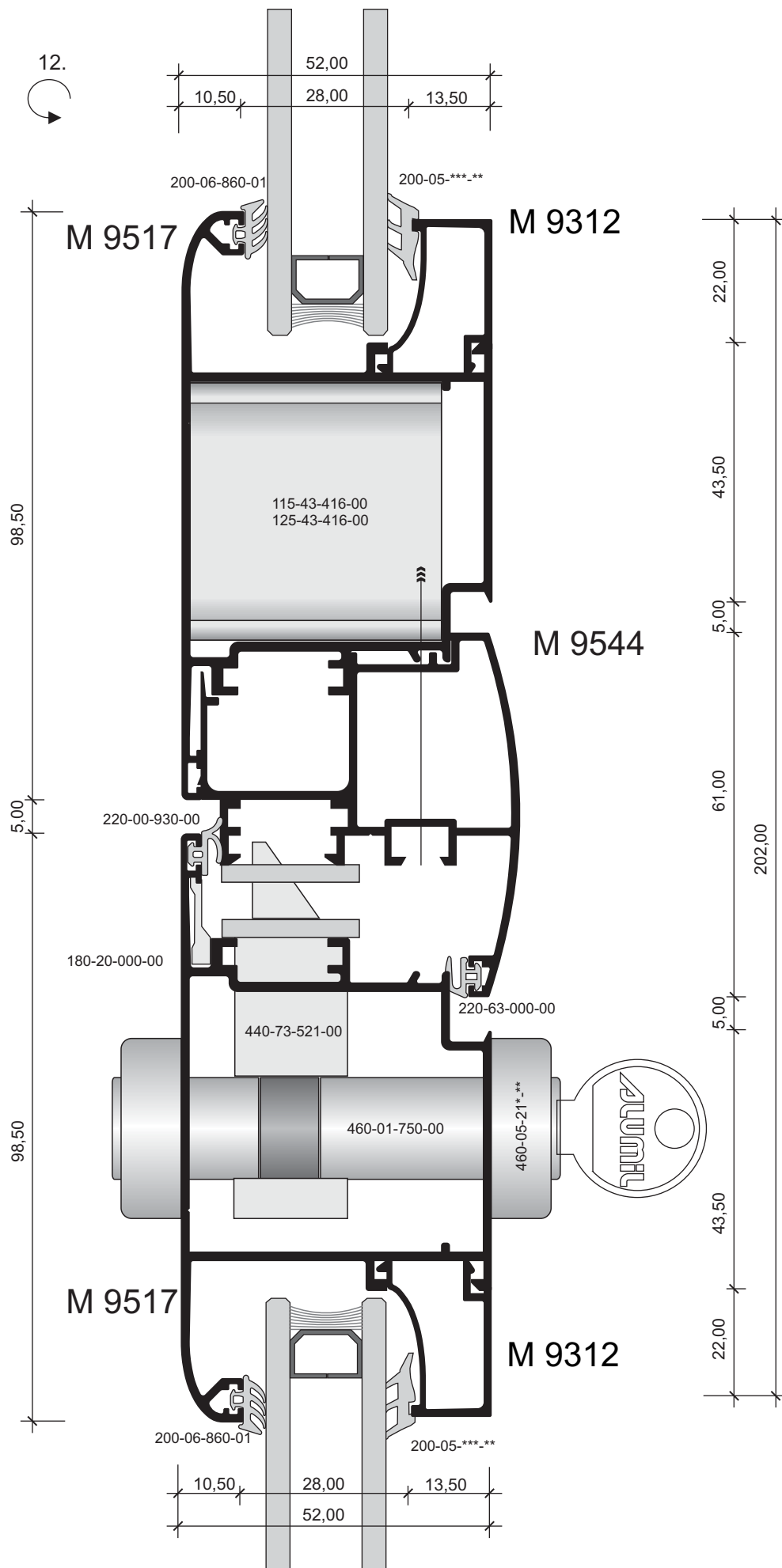
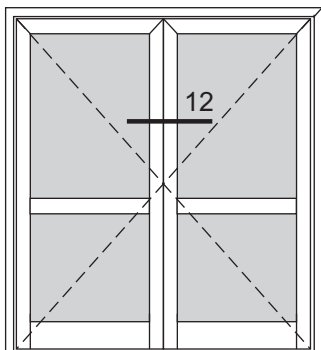

13.

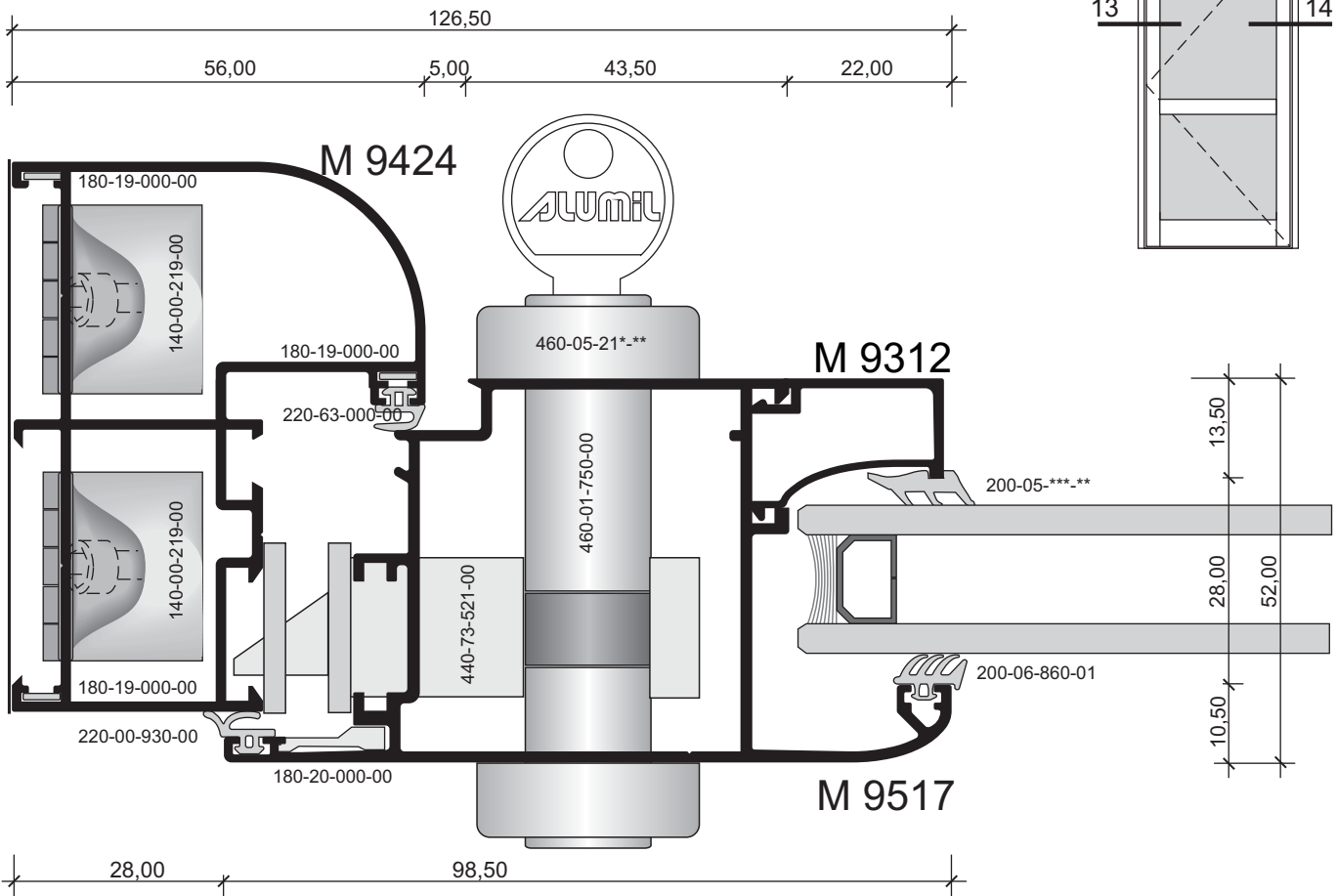



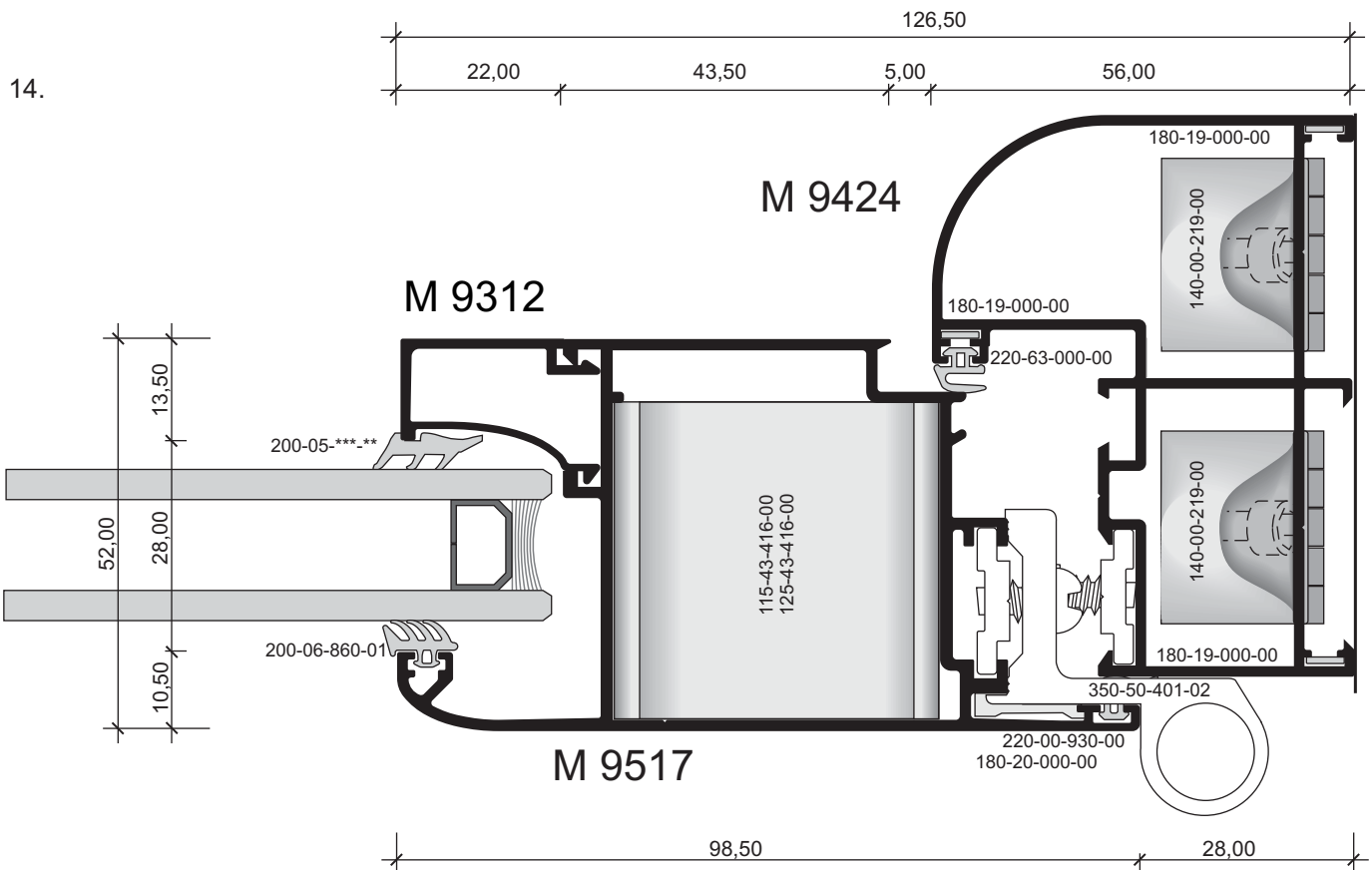







14.

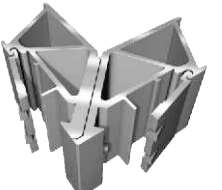
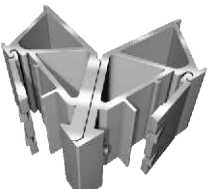
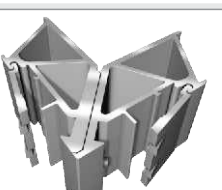





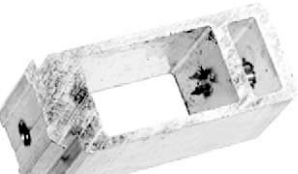







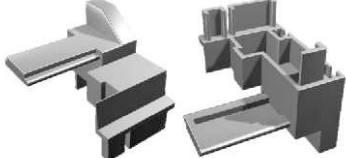





# Pribori i okovi Accessories

115-14-***-**		<p>KAT.BR.: <b>115-14-***-**</b> Stock No :            ART. No: <b>115-14-***-**</b></p> <p>OPIS / DESCRIPTION : KRUTA VEZA / PRESS CORNER</p> <p>MATERIJAL / MATERIAL :ALUMINIJUM / ALUMINIUM</p> <p>KAT.BR.: 115-14-418-00, 115-14-508-00            ART. No:</p>
115-23-***-**		<p>KAT.BR.: <b>115-23-***-**</b> Stock No :            ART. No: <b>115-23-***-**</b></p> <p>OPIS / DESCRIPTION : KRUTA VEZA / PRESS CORNER</p> <p>MATERIJAL / MATERIAL :ALUMINIJUM / ALUMINIUM</p> <p>KAT.BR.: 115-23-416-00, 115-23-121-00            ART. No:</p>
115-33-270-00		<p>KAT.BR.: <b>115-33-270-00</b> Stock No :            ART. No: <b>115-33-270-00</b></p> <p>OPIS / DESCRIPTION : KRUTA VEZA / PRESS CORNER</p> <p>MATERIJAL / MATERIAL :ALUMINIJUM / ALUMINIUM</p> <p>BOJA / COLOR : SIROVO /MILL FINISH</p>
115-38-416-00		<p>KAT.BR.: <b>115-38-416-00</b> Stock No :            ART. No: <b>115-38-416-00</b></p> <p>OPIS / DESCRIPTION : KRUTA VEZA / PRESS CORNER</p> <p>MATERIJAL / MATERIAL :ALUMINIJUM / ALUMINIUM</p> <p>BOJA / COLOR : SIROVO /MILL FINISH</p>
115-43-416-00		<p>KAT.BR.: <b>115-43-416-00</b> Stock No :            ART. No: <b>115-43-416-00</b></p> <p>OPIS / DESCRIPTION : KRUTA VEZA / PRESS CORNER</p> <p>MATERIJAL / MATERIAL :ALUMINIJUM / ALUMINIUM</p> <p>BOJA / COLOR : SIROVO / MILL FINISH</p>
125-23-383-00		<p>KAT.BR.: <b>125-23-383-00</b> Stock No :            ART. No: <b>125-23-383-00</b></p> <p>OPIS / DESCRIPTION : RASTAVLJIVA VEZA / SCREW CORNER</p> <p>MATERIJAL / MATERIAL :ALUMINIJUM / ALUMINIUM</p> <p>KAT.BR.:            ART. No:</p>
125-33-270-00		<p>KAT.BR.: <b>125-33-270-00</b> Stock No :            ART. No: <b>125-33-270-00</b></p> <p>OPIS / DESCRIPTION : RASTAVLJIVA VEZA / SCREW CORNER</p> <p>MATERIJAL / MATERIAL :ALUMINIJUM / ALUMINIUM</p> <p>KAT.BR.:            ART. No:</p>
125-38-416-00		<p>KAT.BR.: <b>125-38-416-00</b> Stock No :            ART. No: <b>125-38-416-00</b></p> <p>OPIS / DESCRIPTION : RASTAVLJIVA VEZA / SCREW CORNER</p> <p>MATERIJAL / MATERIAL :ALUMINIJUM / ALUMINIUM</p> <p>BOJA / COLOR : SIROVO / MILL FINISH</p>

125-43-416-00		KAT.BR. : 125-43-416-00 ART. No. : 125-43-416-00	Stock No :	OPIS / DESCRIPTION : RASTAVLJIVA VEZA / SCREW CORNER	MATERIJAL / MATERIAL : ALUMINIJUM / ALUMINIUM	BOJA / COLOR : SIROVO / MILL FINISH
140-00-219-00		KAT.BR. : 140-00-219-00 ART. No. : 140-00-219-00	Stock No :	OPIS / DESCRIPTION : RASTAVLJIVA VEZA / SCREW CORNER	MATERIJAL / MATERIAL : ČELIK / STEEL	BOJA / COLOR :
140-11-420-00		KAT.BR. : 140-11-420-00 ART. No. : 140-11-420-00	Stock No :	OPIS / DESCRIPTION : RASTAVLJIVA VEZA / SCREW CORNER	MATERIJAL / MATERIAL : LIVENI AL / DIE-CAST AL PAKOVANJE / PACKAGE :	BOJA / COLOR : SIROVO / MILL DIMENZIJE / DIMENSION :
140-38-420-00		KAT.BR. : 140-38-420-00 ART. No. : 140-38-420-00	Stock No :	OPIS / DESCRIPTION : RASTAVLJIVA VEZA / SCREW CORNER	MATERIJAL / MATERIAL : LIVENI AL / DIE-CAST AL PAKOVANJE / PACKAGE :	BOJA / COLOR : SIROVO / MILL DIMENZIJE / DIMENSION :
3515		KAT.BR. : 3515 ART. No. : 3515	Stock No :	OPIS / DESCRIPTION : RASTAVLJIVA VEZA / SCREW CORNER	MATERIJAL / MATERIAL : LIVENI AL / DIE-CAST AL PAKOVANJE / PACKAGE :	BOJA / COLOR : SIROVO / MILL FINISH DIMENZIJE / DIMENSION : 22.6x41.3
2741		KAT.BR. : 2741 ART. No. : 2741	Stock No :	OPIS / DESCRIPTION : RASTAVLJIVA VEZA / SCREW CORNER	MATERIJAL / MATERIAL : LIVENI AL / DIE-CAST AL PAKOVANJE / PACKAGE :	BOJA / COLOR : SIROVO / MILL FINISH DIMENZIJE / DIMENSION : 32.7x26.4
160-11-2xx-00		KAT.BR. : 160-11-2xx-00 ART. No. : 160-11-2xx-00	Stock No :	OPIS / DESCRIPTION : KRUTA VEZA ZA "T" PREČKU / T - CONNECTOR	MATERIJAL / MATERIAL : ALUMINIJUM / ALUMINIUM PAKOVANJE / PACKAGE :	BOJA / COLOR : SIROVO / MILL FINISH OZNAKA / CODE : 160-11-211-00 160-11-233-00
160-33-001-00		KAT.BR. : 160-33-001-00 ART. No. : 160-33-001-00	Stock No :	OPIS / DESCRIPTION : VEZA ZA "T" PREČKU / T - CONNECTOR	MATERIJAL / MATERIAL : ALUMINIJUM / ALUMINIUM PAKOVANJE / PACKAGE :	BOJA / COLOR :

<p>165-00-001-00</p> 	<p>KAT.BR. : 165-00-001-00 ART. No. : 165-00-001-00 Stock No :</p> <p>OPIS / DESCRIPTION : ŠABLON / DRILLING GUIDE</p> <p>MATERIJAL / MATERIAL : PAKOVANJE / PACKAGE :</p> <p>BOJA / COLOR :</p>
<p>470-11-835-00</p> 	<p>KAT.BR. : 470-11-835-00 ART. No. : 470-11-835-00 Stock No :</p> <p>OPIS / DESCRIPTION : KLIN ZA "T" PREČKU Ø 6 / BREAK AWAY NAIL FOR T</p> <p>MATERIJAL / MATERIAL : ČELIK / STEEL PAKOVANJE / PACKAGE :</p> <p>BOJA / COLOR :</p>
<p>180-19-000-00</p> 	<p>KAT.BR. : 180-19-000-00 ART. No. : 180-19-000-00 Stock No :</p> <p>OPIS / DESCRIPTION : DODATNA VEZA / ALIGNMENT CORNER</p> <p>MATERIJAL / MATERIAL : ČELIK / STEEL PAKOVANJE / PACKAGE :</p> <p>BOJA / COLOR :</p>
<p>180-20-000-00</p> 	<p>KAT.BR. : 180-20-000-00 ART. No. : 180-20-000-00 Stock No :</p> <p>OPIS / DESCRIPTION : DODATNA VEZA / ALIGNMENT CORNER</p> <p>MATERIJAL / MATERIAL : POLIAMID / POLYAMIDE PAKOVANJE / PACKAGE :</p> <p>BOJA / COLOR : CRNA / BLACK</p>
<p>180-11-118-00</p> 	<p>KAT.BR. : 180-11-118-00 ART. No. : 180-11-118-00 Stock No :</p> <p>OPIS / DESCRIPTION : UGLIĆ / ALIGNMENT CORNER</p> <p>MATERIJAL / MATERIAL : POLIAMID / POLYAMIDE PAKOVANJE / PACKAGE :</p> <p>BOJA / COLOR : CRNA / BLACK PROFIL / PROFILE : M11118</p>
<p>300-09-304-03</p> 	<p>KAT.BR. : 300-09-304-03 ART. No. : 300-09-304-03 Stock No :</p> <p>OPIS / DESCRIPTION : ČEP ZA SREDNJU PREČKU / END COVER</p> <p>MATERIJAL / MATERIAL : POLIAMID / POLYAMIDE PAKOVANJE / PACKAGE :</p> <p>BOJA / COLOR : PROFIL / PROFILE : M9504</p>
<p>300-09-544-00</p> 	<p>KAT.BR. : 300-09-544-00 ART. No. : 300-09-544-00 Stock No :</p> <p>OPIS / DESCRIPTION : ČEP ZA SREDNJU PREČKU / END COVER</p> <p>MATERIJAL / MATERIAL : POLIAMID / POLYAMIDE PAKOVANJE / PACKAGE :</p> <p>BOJA / COLOR : CRNA / BLACK PROFIL / PROFILE : M9544</p>
<p>310-11-501-00</p> 	<p>KAT.BR. : 310-11-501-00 ART. No. : 310-11-501-00 Stock No :</p> <p>OPIS / DESCRIPTION : ČEP ZA TEHNOLOŠKI OTVOR / WATER CAP</p> <p>MATERIJAL / MATERIAL : POLIAMID / POLYAMIDE PAKOVANJE / PACKAGE :</p> <p>BOJA / COLOR : BIJELA / WHITE, CRNA / BLACK</p>

<p>310-11-116-00</p> 	<p>KAT.BR. ART. No: <b>310-11-116-00</b> Stock No :</p> <p>OPIS / DESCRIPTION : ČEP / END COVER</p> <p>MATERIJAL / MATERIAL : POLIAMID / POLYAMIDE PAKOVANJE / PACKAGE :</p> <p>BOJA / COLOR : CRNA / BLACK PROFIL / PROFILE : M11116</p>
<p>310-09-317-00</p> 	<p>KAT.BR. ART. No: <b>310-09-317-00</b> Stock No :</p> <p>OPIS / DESCRIPTION : ČEP ZA OKAPNICU/ END COVER</p> <p>MATERIJAL / MATERIAL POLIAMID / POLYAMIDE PAKOVANJE / PACKAGE :</p> <p>BOJA / COLOR : BIJELA/WHITE -CRNA/BLACK PROFIL / PROFILE : M9317</p>
<p>310-09-346-00</p> 	<p>KAT.BR. ART. No: <b>310-09-346-00</b> Stock No :</p> <p>OPIS / DESCRIPTION : ČEP ZA PRAG / END CAP FOR TRESHOLD</p> <p>MATERIJAL / MATERIAL : PAKOVANJE / PACKAGE :</p> <p>BOJA / COLOR : PROFIL / PROFILE :</p>
<p>310-09-431-00</p> 	<p>KAT.BR. ART. No: <b>310-09-431-00</b> Stock No :</p> <p>OPIS / DESCRIPTION : ZAVRŠNI POKLOPAC / ENDCAP</p> <p>MATERIJAL / MATERIAL : PAKOVANJE / PACKAGE :</p> <p>BOJA / COLOR : PROFIL / PROFILE : M9431</p>
<p>170-60-561-00</p> 	<p>KAT.BR. ART No: <b>170-60-561-00</b> Stock No :</p> <p>OPIS : UGAO ZA LAJSNU M11461 DESCRIPTION CORNER PIECE FOR GLAZING BEAD</p> <p>MATERIJAL / MATERIAL : LIVENI AL / DIE CAST</p> <p>BOJA : SIROVO COLOR : MILL FINISH</p> <p>KAT.BR. : 170-60-561-02 BIJELA-WHITE, ART No: 170-60-561-03 CRNA - BLACK</p> <p>PAKOVANJE : PACKAGE :</p> <p>DIMENZIJE : DIMENSION :</p>
<p>170-60-562-00</p> 	<p>KAT.BR. ART No: <b>170-60-562-00</b> Stock No :</p> <p>OPIS : UGAO ZA LAJSNU M11462 DESCRIPTION CORNER PIECE FOR GLAZING BEAD</p> <p>MATERIJAL / MATERIAL : LIVENI AL / DIE CAST</p> <p>BOJA : SIROVO COLOR : MILL FINISH</p> <p>KAT.BR. : 170-60-562-02 BIJELA-WHITE, ART No: 170-60-562-03 CRNA - BLACK</p> <p>PAKOVANJE : PACKAGE :</p> <p>DIMENZIJE : DIMENSION :</p>
<p>170-60-563-00</p> 	<p>KAT.BR. ART No: <b>170-60-563-00</b> Stock No :</p> <p>OPIS : UGAO ZA LAJSNU M11463 DESCRIPTION CORNER PIECE FOR GLAZING BEAD</p> <p>MATERIJAL / MATERIAL : LIVENI AL / DIE CAST</p> <p>BOJA : SIROVO COLOR : MILL FINISH</p> <p>KAT.BR. : 170-60-563-02 BIJELA-WHITE, ART No: 170-60-563-03 CRNA - BLACK</p> <p>PAKOVANJE : PACKAGE :</p> <p>DIMENZIJE : DIMENSION :</p>
<p>170-60-564-00</p> 	<p>KAT.BR. ART No: <b>170-60-564-00</b> Stock No :</p> <p>OPIS : UGAO ZA LAJSNU M11464 DESCRIPTION CORNER PIECE FOR GLAZING BEAD</p> <p>MATERIJAL / MATERIAL : LIVENI AL / DIE CAST</p> <p>BOJA : SIROVO COLOR : MILL FINISH</p> <p>KAT.BR. : 170-60-564-02 BIJELA-WHITE, ART No: 170-60-564-03 CRNA - BLACK</p> <p>PAKOVANJE : PACKAGE :</p> <p>DIMENZIJE : DIMENSION :</p>

	<p>KAT.BR. / ART. No <b>210-74-006-00</b> Stock No : <b>İİ7406</b></p> <p>OPIS / DESCRIPTION : CENTRALNA ZAPTIVKA / CENTRAL GASKET</p> <p>MATERIJAL / MATERIAL : EPDM BOJA / COLOR: CRNA / BLACK</p>
	<p>KAT.BR. / ART. No <b>220-00-930-00</b> Stock No : <b>MO9300</b></p> <p>OPIS / DESCRIPTION : ZAPTIVKA / GASKET</p> <p>MATERIJAL / MATERIAL : EPDM BOJA / COLOR: CRNA / BLACK</p>
	<p>KAT.BR. / ART. No <b>220-63-000-00</b> Stock No : <b>İİ6300</b></p> <p>OPIS / DESCRIPTION : ZAPTIVKA / GASKET</p> <p>MATERIJAL / MATERIAL : EPDM BOJA / COLOR: CRNA / BLACK</p>
	<p>KAT.BR. / ART. No <b>200-05-506-00</b> Stock No :</p> <p>OPIS / DESCRIPTION : ZAPTIVKA ZA STAKLO 5 - 6 mm / GLAZING GASKET 5 - 6</p> <p>MATERIJAL / MATERIAL : EPDM BOJA / COLOR: CRNA / BLACK</p>
	<p>KAT.BR. / ART. No <b>910-00-022-35</b> Stock No :</p> <p>OPIS / DESCRIPTION : ZAPTIVKA ZA STAKLO 2,5 mm / GLAZING GASKET 2,5 mm</p> <p>MATERIJAL / MATERIAL : EPDM BOJA / COLOR: CRNA / BLACK</p>
	<p>KAT.BR. / ART. No <b>200-05-304-00</b></p> <p>OPIS / DESCRIPTION : ZAPTIVKA 3 - 4 mm / GLAZING GASKET 3 - 4 mm</p> <p>MATERIJAL / MATERIAL : EPDM BOJA / COLOR: CRNA / BLACK</p>
	<p>KAT.BR. / ART. No <b>200-06-860-00</b></p> <p>OPIS / DESCRIPTION : ZAPTIVKA 4 mm / GLAZING GASKET 4 mm</p> <p>MATERIJAL / MATERIAL : EPDM BOJA / COLOR: CRNA / BLACK</p>
	<p>KAT.BR. / ART. No <b>250-11-170-00</b></p> <p>OPIS / DESCRIPTION : ZAPTIVKA / GASKET</p> <p>MATERIJAL / MATERIAL : EPDM BOJA / COLOR: CRNA / BLACK</p>
	<p>KAT.BR. / ART. No <b>250-11-270-00</b></p> <p>OPIS / DESCRIPTION : ZAPTIVKA / GASKET</p> <p>MATERIJAL / MATERIAL : EPDM BOJA / COLOR: CRNA / BLACK</p>





- Telefoni: ++387 56 733 750; 710 571; 710-690
- Fax: ++387 56 733 196; 710 681
- E-mail: [bhaluminium@alpro-vl.com](mailto:bhaluminium@alpro-vl.com)
- Web: [www.alumil.com](http://www.alumil.com), [www.alumil.ba](http://www.alumil.ba), [www.alpro-vl.com](http://www.alpro-vl.com)